

tuttnauer

Sterilization & Infection Control Products



OPERATION & MAINTENANCE MANUAL

Table-Top Autoclaves
Models 1730, 2340, 2540, 3545, 3850, 3870M



MERCOFRAMES OPTICAL CORP

5555 Nw 74 Ave. Miami, Fl 33166 305-882-0120

www.mercoframes.com sales@mercoframes.net

TABLE OF CONTENTS

PARAGRAPH	PAGE NO.
1. GENERAL	4
1.1 Incoming Inspection	4
1.2 Warranty	4
1.3 Warranty Statement	4
2. TECHNICAL DATA	5
2.1 Introduction	5
2.2 Operating Condition	5
2.3 Standards	5
2.4 Storage conditions	5
2.5 Construction	6
2.6 Mains	6
2.7 Waste Water Disposal	6
2.8 Environment Emission Information	6
2.9 Dimensions	7
2.10 Technical Specifications	8
2.11 Electrical Data	9
2.12 Symbol Description	9
3. DESCRIPTION OF COMPONENTS	11
3.1 Control Panel	11
3.2 Other Components	11
4. INSTALLATION, PLACING AND LEVELING INSTRUCTIONS	12
4.1 leveling	12
4.2 Water quantity for a cycle	13
4.3 Lifting and Carrying	13
4.4 Loading and Unloading the Device	13
5. WATER QUALITY	14
6. PREPARATION BEFORE STERILIZATION	15
7. OPERATION	19
8. MAINTENANCE INSTRUCTIONS	24
8.1 Preventive and Scheduled Maintenance	24
8.2 Draining the Reservoir	25
8.3 Replacing the Door Gasket	26
8.4 Checking the Safety Valve	27
9. CLEANING TABLE TOP AUTOCLAVES WITH CHAMBER BRITE™	28

TABLE OF CONTENT (Cont.)
SERVICE AND MAINTENANCE SECTION

PARAGRAPH	PAGE NO.
10. TROUBLESHOOTING	31
11. MAINTAINING AND REPLACING PARTS	34
11.1 Safety Tests after Repair	34
11.2 Dismantling the Outer Cover of the Autoclave.	35
11.3 Cleaning and Replacing Air Trap Jet	36
11.4 Replacing the Safety Valve	36
11.5 Replacing the Circuit Breaker	37
11.6 Temperature Safety Thermostat	38
11.7 Raising the Working the Temperature of the Safety Thermostat	38
11.8 Cut-Off Thermostat	39
11.9 Replacing Heating Elements	39
11.10 Replacing Multi-Purpose Valve	40
11.11 Unclogging the multi-Purpose Valve or Chamber	41
11.12 Pressure Door Lock System	41
11.13 Replacing the Door Bellows	42
11.14 Replacing the thermostat B10	43
11.15 Replacement of the Door Cover	44
11.16 Replacing the Locking Device	45
11.17 Replacing the Door Switch	46
12. LIST OF ACSSESORIES	53
13. LIST OF SPARE PARTS	54
14. CONVERSION TABLE	57

TABLE OF CONTENT (Cont.)

DRAWINGS	PAGE NO.
<i>Front View</i>	<i>10</i>
<i>Closing Device</i>	<i>46</i>
<i>Multi-Purpose Valve Assembly CMT240-0027</i>	<i>47</i>
<i>General View of Vessel, Door and Accessories</i>	<i>48</i>
<i>Autoclave Cover</i>	<i>49</i>
<i>Tray Handle CMT240-0001</i>	<i>50</i>
<i>Pouch Rack</i>	<i>50</i>
<i>Tray</i>	<i>50</i>
<i>Tray Holder</i>	<i>51</i>
<i>Alternative Tray Holder</i>	<i>51</i>
<i>Door Tightening Bolt – Assembly</i>	<i>52</i>
<i>Drawing of Electrical System of Table Autoclave Model 1730M</i>	<i>58</i>
<i>Drawing of Electrical System of Table Autoclave Models 2340/2540 M</i>	<i>59</i>
<i>Drawing of Electric System of Table Autoclave Model 3545 M</i>	<i>60</i>
<i>Drawing of Electric System of Table Autoclave Model 3850 M</i>	<i>61</i>
<i>Drawing of Electrical System of Table Autoclave Model 3870 M</i>	<i>62</i>
<i>Piping Diagram Table Top Autoclave Models M</i>	<i>63</i>

1. GENERAL



Read the Operating Instructions carefully, before beginning any operation on the autoclave!

1.1 *Incoming Inspection*

Upon receiving your Tuttnauer Autoclave carefully inspect the outside of the shipping carton for signs of damage. If any damage to the carton is found note the location with respect to the autoclave and check that area of the autoclave carefully once it is fully unpacked. Observe packing method and retain packing materials until the unit has been inspected. Mechanical inspection involves checking for signs of physical damage such as: scratched panel surfaces, broken knobs, etc.

If any damage is found contact your dealer as soon as possible so that they can file a claim with the shipping carrier and also notify Tuttnauer.

All Tuttnauer products are carefully inspected prior to shipment and all reasonable precautions are taken in preparing them for shipment to assure safe arrival at their destination.

Note: Lifting and carrying should always be done by two people.

1.2 *Warranty*

For warranty information on this unit please contact your dealer or Brinkmann Instruments at one of the #'s listed below:

☒ Brinkmann Instruments, Inc., One Cantiague Road. P.O. Box 1019, Westbury, NY 11590-0207, ☎ (800) 645-3050, ☐ Fax: (516) 334-7506

☒ Brinkmann Instruments (Canada) Ltd., 6670 Campobello Road, Mississauga, Ontario L5N 2L8, ☎ (800) 262-8715, ☐ Fax: (905) 826-5425

2. **TECHNICAL DATA**

2.1 **Introduction**

The table-top autoclave is pressure controlled automatically. It is especially designed to meet the needs of effective and safe sterilization in all kinds of dental and medical clinics, first aid rooms, small laboratories etc.

The autoclave models M are electrically heated sterilizers of different dimensions, using steam as the sterilizing agent.

It is easy to operate using the operating manual. Operator can choose the required sterilization temperature range 212-273°F (100-134°C) thus allow the instrument to be used as a sterilizer at 250°F (121°C) or 273°F (134°C). The low temperature range 212-250°F (100-121°C) is designed to meet sterilization requirement when heat-sensitive material is sterilized. The autoclave is specially designed for sterilization of infectious waste materials prior to their disposal.

This manual is intended to give the user a general understanding of how the autoclave works and indicate the best ways to operate and take care of it in order to obtain optimum results and a trouble-free operation. However, since the autoclave is built using high technology sensitive components, no attempt should be made by the user or any other unauthorized person to repair or re-calibrate it.

Only technical personnel having proper qualifications, and holding the technical documentation and adequate test instrumentation are authorized to service the instruments.

2.2 **Operating Condition**

This device is to be used for indoor use.

The sterilizer should be loaded only with autoclavable material.

The environment shall not exceed an ambient temperature of 40°C and a relative humidity of 85%.

2.3 **Standards**

2.3.1 **Technical standards**

1. A.S.M.E. Code, Section VIII div.1 for unfired pressure vessels.
2. AAMI/ANSI ST-55:2001 Table-Top steam sterilizers.
3. UL61010-1 General Safety.
4. UL61010-2-041 Particular Safety for Autoclaves.

2.3.1 **Quality standards**

1. EN ISO 9001:2000– Quality System
2. ISO 13485 – Quality systems – Medical devices – Particular requirements for the application of ISO 9001.

2.4 **Storage conditions**

The packed or unpacked autoclave shall be stored in “indoor conditions” (protected from rain and water).

2.5 **Construction**

The main parts of the autoclave are made of materials as indicated below:

- ◆ Chamber is built of stainless steel 316 L.
- ◆ Door is made of stainless steel 304.
- ◆ Trays are made of stainless steel 316.
- ◆ Door handle is made of hard plastic material that is safe to touch and thermo-insulated.
- ◆ Water reservoir is made of hard plastic material.

2.6 **Mains**

For proper operation, these are the required mains:

Electricity: 230V, 15A fuse or 120 V. 15A fuse as appropriate.

The network must be protected with a current leakage safety relay.

2.7 **Waste Water Disposal**

Caution !



Waste-water may be brought into the public water piping in accordance with the local rules or requirements. I.e. only non-hazardous liquids may be disposed in public sewage!

2.8 **Environment Emission Information**

- A. The peak sound level generated by the sterilizer is $\ll 78$ / dBA with background noise of 60 dB.
- B. The total heat transmitted by the sterilizer is < 100 W/h for 1730/2340/2540 models and < 150 W/h for 3545/3850/3870 models.

2.9 Dimensions

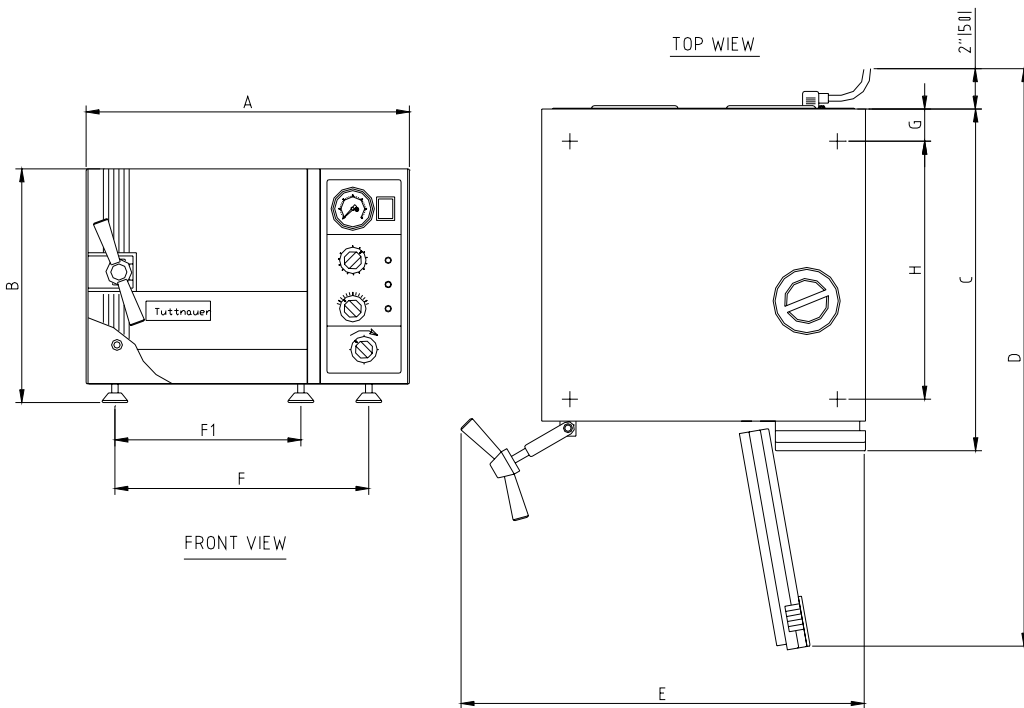

Model	1730		2340		2540		3545		3850		3870		
	Inch	mm	Inch	mm	Inch	mm	Inch	mm	Inch	mm	Inch	mm	
Overall Dimensions	A	17.4	440	20.0	510	20.0	510	23.2	590	26.0	660	26.0	660
	B	12.0	305	14.4	365	14.4	365	17.7	450	20.7	525	20.7	525
	C	17.9	455	21.5	545	21.5	545	21.9	556	27.5	695	34.5	875
Maximum dimensions (door open)	D	29.5	750	35.8	910	35.8	910	39.0	990	45.5	1155	53.0	1335
	E	22.0	560	25.8	655	25.8	655	29.7	755	32.0	815	32.0	815
Distance between supporting legs F1-front legs F -rear legs	F1	9.2	234	11.8	299	11.8	299	19.2	488	17.7	450	17.7	450
	F	13.4	339	16.6	422	16.6	422	14.6	371	22.2	564	22.2	564
	G	2.0	50	2.0	50	2.0	50	2.0	50	2.0	50	2.0	50
	H	12.4	315	15.8	400	15.8	400	15.2	386	21.8	555	30.5	725
Diameter	6.7	170	9.1	230	10	254	12.3	312	15.1	384	15.1	384	
Depth	13.4	340	18.5	470	18.7	475	15.4	391	22.8	580	29.9	760	

2.10 Technical Specifications

<i>Model</i>	Chamber dimensions DIA x D	Volume of chamber	Tray dimensions W X D X H	No. of trays	No. of standard Cassettes (Optional)		Shipping Weight	Shipping Volume
					Half	full		
1730	17 x 34 cm (6.7" x 13.4")	7.5 liters. (2 US gal.)	12 x 29.5 x 2 cm (4.7" x 11.6" x 0.8")	3	2	—	24.8 kgs. (54.7 lbs.)	0.18 m ³ (6.35 cu.f.)
2340	23 x 47 cm (9" x 18.5")	19 liters. (5 US gal.)	17 x 41.5 x 2cm (6.7" x 16.3" x 0.8")	3	2	2	35.7 kgs. (78.7 lbs.)	0.27m ³ (9.4 cu.f.)
2540	25.4 x 47.5cm (10" x 18.7")	23 liters. (6 US gal.)	17 x 41.5 x 2 cm (6.7" x 16.3" x 0.8")	4	3	3	47.8 kgs. (83.3 lbs.)	0.27m ³ (9.4 cu. f.)
3545	31.2 x 39.1 (12.3" x 15.4")	34.4 liters (7.8 US gal.)	25.6 x 40.8 x 2.5 cm (10.1" x 16.1" x 1") 19.8 x 40.8 x 2.5 cm (7.8" x 16.1" x 1")	2	4	4	60 kgs (132 lbs.)	0.35 m ³ (12.4 cu.f)
3850	38 x 58 cm. (15" x 23")	65 liters. (17US gal)	28 x 50 x 2.5 cm (11" x 20 " x 1") 35 x 50 x 2.5cm (14" x 20 " x 1")	2	—	10	89 kgs. (196 lbs.)	0.63 m ³ (22.2cu.f.)
3870	38x76 cm (15" x 30")	84 liters. (22 US gal)	28 x 67 x 2.5cm (11" x 26" x 1") 35 x 67 x 2.5 (14" x 26" x 1")	2	—	15	102 kgs. (225 lbs.)	0.76m ³ (26.8cu.f)

2.11 Electrical Data

<i>Model</i>	<i>1730</i>	<i>2340</i>	<i>2540</i>	<i>3545</i>	<i>3850</i>	<i>3870</i>
<i>Specifications</i>						
Total power model 120V	8.8A	11.7A	11.7A	—	—	—
Total power model 230V	4.6A	6.0A	6.0A	10.4A	10.4A	13A
Heaters W	1050	1400	1400	1800	2400	3000
Protection against electrical shock	Class I (IEC 60601-1)					

2.12 Symbol Description



Caution! Consult accompanying documents



Caution! Hot Surface.



Caution! Hot steam.



Ground

FRONT VIEW

1. Front legs
2. Reservoir water drain valve.
3. Door tightening bolt
4. Door Micro-switch
5. Autoclave cover
6. Water reservoir cover
7. Water reservoir
8. Safety valve
9. Air trap jet
10. Pressure gauge
11. Timer
12. Pressure switch (B10) knob
13. Multipurpose valve
14. Heat indicator light
15. Dry indicator light
16. Power indicator light
17. Main power switch

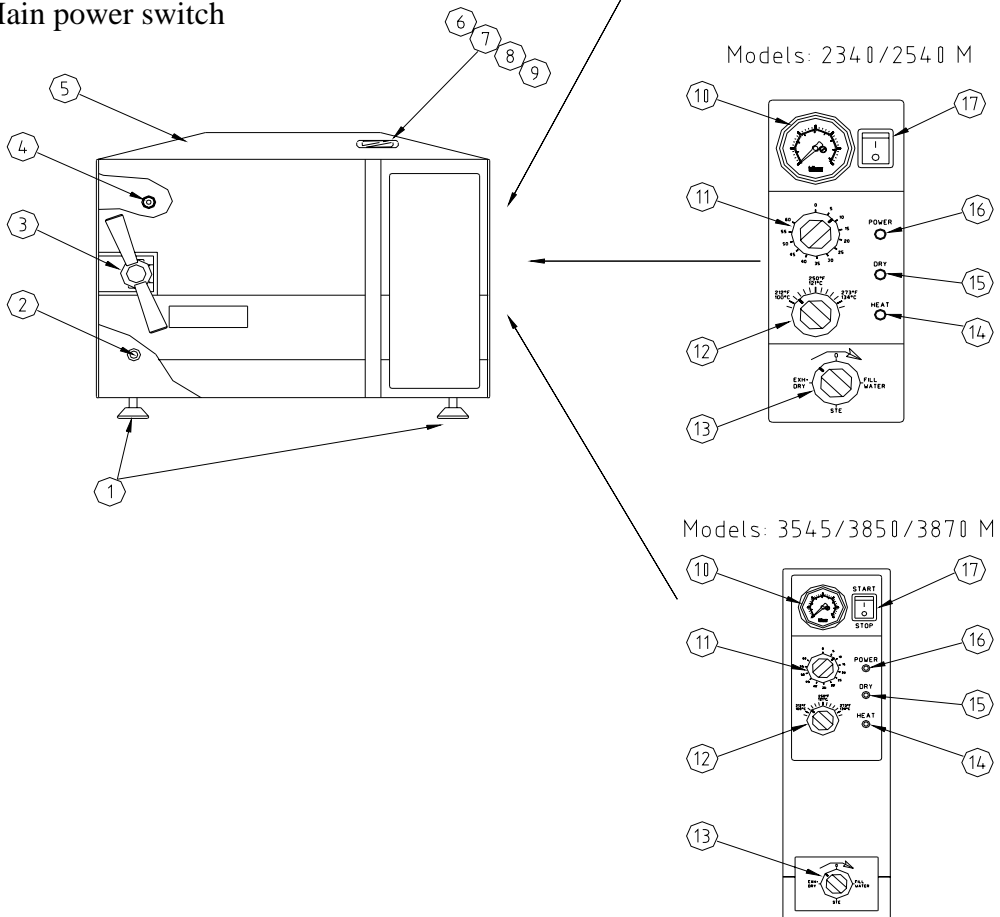

3. **DESCRIPTION OF COMPONENTS**
The item numbers refer to the front view in the previous page

3.1 **Control Panel**

<i>Item</i>	<i>Description</i>	<i>Operation</i>	
10.	PRESSURE GAUGE	0-60 psi, (0-4bar) indicates the chamber pressure.	
11.	TIMER 0-60 min.	Sets the sterilization and drying cycles and automatically switches off the power supply to the heating elements when the times reaches "0".	
12.	PRESSURE SWITCH	Sets the sterilization temperature for each desired material 221-274°F, (105-134°C). See page 18.	
13.	MULTI-PURPOSE VALVE	Position	
		1. FILL	Water flows from the water reservoir into the chamber.
		2. STE.	Valve closed to all directions.
		3. EXH.& DRY	Exhausts the steam from the chamber into the water reservoir after the sterilization cycle is finished.
		4. " 0 "	Heating elements are disconnected, no cycle is in progress.
14.	HEAT INDICATOR LIGHT	Lights to indicate that the heaters are activated. They will shut off when the temperature reaches the desired value.	
15.	DRY INDICATOR LIGHT	Lights to indicate that drying cycle is in process.	
16.	POWER INDICATOR LIGHT	Light to indicate that the main switch is on.	
17.	MAIN SWITCH-	Main power switch, which supplies electric power to the autoclave.	

3.2 **Other Components**

<i>Item</i>	<i>Description</i>	<i>Operation</i>
2.	WATER DRAIN VALVE	Enables the drainage of water from the reservoir.
7.	WATER RESERVOIR	Holds ample water for sterilization and also serves as a steam condenser.
8.	SAFETY VALVE	Blows off when pressure in the chamber reaches 40psi (2.7Bar) in models 1730, 2340, 2540 and 37psi in models 3545, 3850, 3870. This type of safety valve is A.S.M.E. approved (located in water reservoir).
9.	AIR TRAP JET	Prevents air pockets in the chamber to ensure adequate sterilization (located in the water reservoir).
◆	SAFETY THERMOSTAT	Prevents over-heating during the drying stage.
◆	CUT-OUT THERMOSTAT	Cuts off the power in case of overheating if the safety thermostat does not operate. This thermostat does not reconnect automatically but must be reset.

4. **INSTALLATION, PLACING AND LEVELING INSTRUCTIONS**

Network



Network and connection should comply with the devices consumption. It must comply with local installation and safety rules and regulations. The voltage supplied to the device must comply with the label $\pm 5\%$.



Caution:

The sterilizer must be placed on a rigid and leveled surface. The stand must be able to hold the load of the device and loaded material.



Note:

Make sure while placing the autoclave, to leave space around the machine, to give the technician access to service the machine.

In order to avoid any injury by electrical hazard, it is mandatory for the customer to have installed an earth leakage relay in the electrical board to which the autoclave is connected.

This relay disconnects all the poles of the electrical power line in case of accidental contact with the instrument metal enclosure, by the operator or another person, leading to a dangerous leakage current.

Note: *Keep the back and the right side of the autoclave approximately 1" (25mm) away from the wall to allow for ventilation.*

Connect the power cord to the socket on the rear side of the autoclave; plug it into the supply socket.

4.1 leveling

The legs (2) of the autoclave are factory set for the autoclave to hold this amount of water when the autoclave stands on a level surface (3). To check the water level fill a beaker (4) with the recommended quantity of water, pour the water into the chamber. The water must reach the indicator groove (1) in front of the chamber.

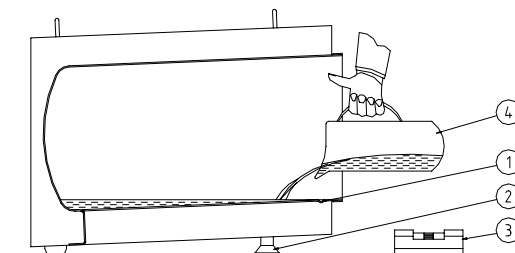

1730		2340/2540		3545		3850		3870	
300 ml	11 ozs.	350 ml	12 ozs.	400 ml	14 ozs.	500 ml	17 ozs.	650 ml	23 ozs.

If it is necessary, raise the front legs in order to get the proper amount of water.

4.2 *Water quantity for a cycle*

The amount of water in the autoclave chamber necessary for each sterilization cycles as follows:

1730		2340/2540		3545		3850		3870	
350 ml.	12 ozs.	450 ml.	16 ozs.	700 ml.	25 ozs.	850 ml.	30 ozs.	1000 ml.	35 ozs.

It is imperative to have the correct amount of water for proper operation of the autoclave!

4.3 *Lifting and Carrying*

Caution:



Before moving the autoclave, make sure that the electric cord is disconnected from the power source and that there is no pressure in the chamber.

- 1. Disconnect the power supply cord.*
- 2. Drain the water from the reservoir and vessel.*

Lifting and carrying should be done by two people.

Do not drop the device!

4.4 *Loading and Unloading the Device*

Protective equipment and clothes should be implemented in accordance to local and national regulations and/or rules!

5. ***WATER QUALITY***

The distilled or mineral – free water supplied to the autoclave should have the physical characteristics and maximum acceptable level of contaminants indicated in the table below:

Physical characteristics and acceptable contaminants levels in water, for sterilizers

Evaporate residue	≤ 15 mg/l
Silica	≤ 2 mg/l
Iron	≤ 0.2mg/l
Cadmium	≤ 0.005 mg/l
Lead	≤ 0.05 mg/l
Rest of heavy metals	≤ 0.1 mg/l
Chloride	≤ 3 mg/l
Phosphate	≤ 0.5 mg/l
Conductivity	≤ 50 µs/cm
pH	6.5 to 8
Appearance	Colourless, clean, without sediment
Hardness	≤ 0.1 mmol/l

Compliance with the above data should be tested in accordance with acknowledged analytical methods, by an authorized laboratory.

Attention:

We recommend testing the water quality once a month. The use of water for autoclaves that does not comply with the table above may have severe impact on the working life of the sterilizer and can invalidate the manufacturer's guarantee.

6. ***PREPARATION BEFORE STERILIZATION***

The purpose of packaging and wrapping of items for sterilization is to provide an effective barrier against sources of potential contamination in order to maintain sterility and to permit aseptic removal of the contents of the pack. Packaging and wrapping materials should permit the removal of air from the pack, penetration of the sterilizing water vapor into the pack and removal of the sterilizing vapor.

The basic principle determining the size, mass and contents of instrument and hollowware packs is that the contents are sterile and dry immediately on completion of the drying cycle and removal of the pack from the sterilizer chamber.

Instruments to be sterilized must be clean, free from any residual matter, such as debris, blood, pads or any other material. Such substances may cause damage to the contents being sterilized and to the sterilizer.

1. Immediately after use, clean instruments thoroughly to dispose of any residue.
2. It is recommended to wash instruments with an ultrasonic cleaner, using detergent and mineral-free water.
3. Launder textile wraps prior to reuse.
4. After cleaning, rinse instruments for 30 seconds. (Follow manufacturer's instructions on the use of products for cleaning and lubricating instruments after using the ultrasonic cleaner).
5. Materials, including materials used for inner wraps, shall be compatible with the item being packed and the sterilizing method selected.
6. Do not place materials to be sterilized directly on the chamber's wall. Place the material only on trays, rack, etc.
7. Before placing an instrument into the sterilizer tray, make sure that instruments which are not of the same metal, (stainless steel, carbon steel, etc.) are separated and placed on different trays.

Note: Check manufacturer's instructions for the sterilization of each item.

8. In case carbon steel instruments are placed on stainless steel trays, the trays should be lined with a towel or paper wrap before placing the instruments on the trays. There should be no direct contact between the carbon steel and the stainless steel trays.

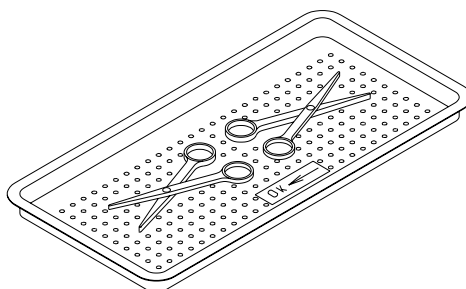

9. All instruments must be sterilized in an open position.
10. Use single-use wraps once only and discard after use.

11. Verify that the packaging method is in accordance with good practice approach and the packaging materials are in accordance with the applicable standards (e.g. EN868 series).
12. Place a sterilization indicator strip in each tray.
13. Place instruments with ratchets opened and unlocked or clipped on the first ratchet position.
14. Disassemble or sufficiently loosen multiple-part instruments prior to packaging to permit the sterilizing agent to come into contact with all parts of the instrument.
15. Tilt on edge items prone to entrap air and moisture, e.g. hollowware, so that only minimal resistance to air removal, the steam passage and condensate will be met.
16. Load items within the boundaries of the tray so that they do not touch the chamber walls, or fall off when the loaded car is inserted into the autoclave.
17. The operator may use racks to allow for adequate separation of packaged instruments.
18. Load trays loosely to capacity.
19. Once a week, use a biological spore test indicator in any load to make sure sterilization is performed.
20. Make sure that all instruments remain apart during the sterilization cycle.
21. Empty canisters should be placed upside-down, in order to prevent accumulation of water.
22. Allow a distance of approximately 2.5 cm (1") between trays to permit steam circulation.
23. ***Wrapped Instruments***
Wrapped instruments should be packed in material that promotes drying such as autoclave bag, autoclave paper, and muslin towels.
It is highly recommended to utilize the Tuttnauer™ Pouch Rack. This rack allows the operator to place pouches on their side, thus increasing the capacity of the autoclave significantly and promoting better drying of the instruments. Contact your dealer for details.

Note:

A table “Suitability of steam sterilization processes for various goods and method of packing” is added to the accompanying documents.

Pouch Rack

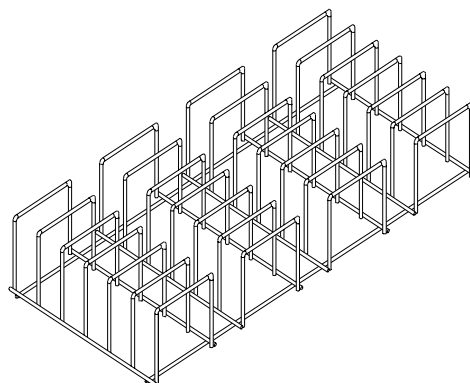

24. Packs

1. Place packs upright on trays, side by side.
2. Packs should not touch the chamber walls.
3. Pack instrument sets in a manner that prevents damage to delicate items.
4. Pack hollowware sets so that all openings face the same direction and so that the contents cannot move inside the pack.
5. Load packs of folded operating room drapes with layers vertical, allowing air to be removed from the packs rapidly.
6. Do not place packs of hollowware and trays of instruments above textile packs or soft goods in order to avoid wetting caused by condensation from items above.
7. Load items packed in flexible packaging materials on edge with paper to laminate, or flat with the paper surface downwards.

Note:

The manufacturer's recommendations shall be observed, concerning the sterilization data for each type of material.

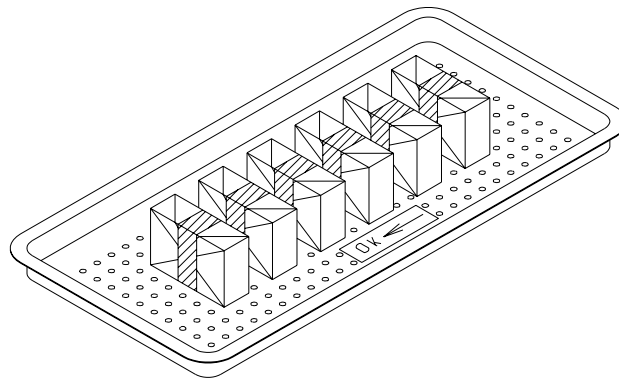

25. Tubing

When placing in a tray, make sure that both ends are open, without sharp bends or twists.

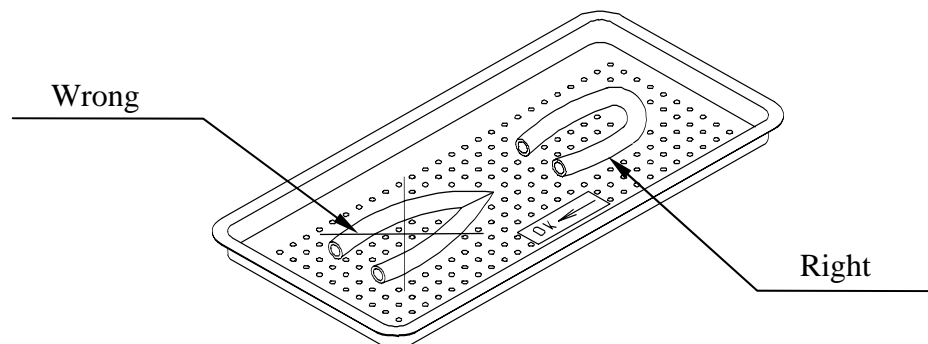

26. *Liquids*

Use only heat-proof glass, filled to 2/3 capacity. Ensure that the glass container is covered, but not sealed to prevent pressure build-up.

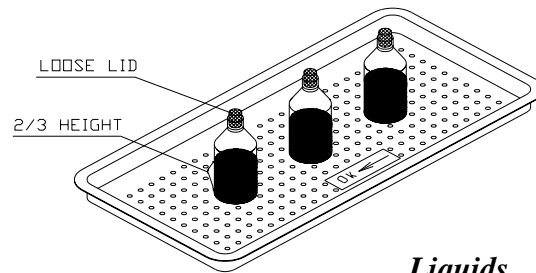

Note: A table of suitability steam sterilization process for various goods and methods of packing is included with accompanying documents.

7. OPERATION



To avoid possible damage, do not leave the autoclave un-attended while in operation

1. Ensure that the drain valve is in a CLOSED position.
 2. Remove the water reservoir cover.
 3. Pour distilled or mineral-free water into the reservoir through the opening on top of the autoclave until it reaches the base of the safety valve holder (the base must no immerse in the water).
- 3.1 Verify that the water quality is according to the requirement specified in para. 7.

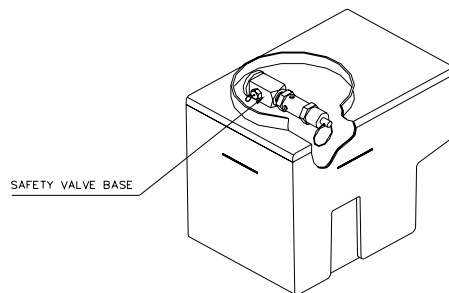

Caution

Under no circumstances should water be filled above the Safety Valve Holder.

Use distilled or mineral-free water only. Tap water may block the hole of the air trap jet. This causes air pockets that prevent the temperature from rising. It is essential that from time to time during the sterilization period, a spray of steam should escape, causing a hissing sound. If no steam is evident, follow instructions for air trap jet cleaning procedure (para. 11.2).

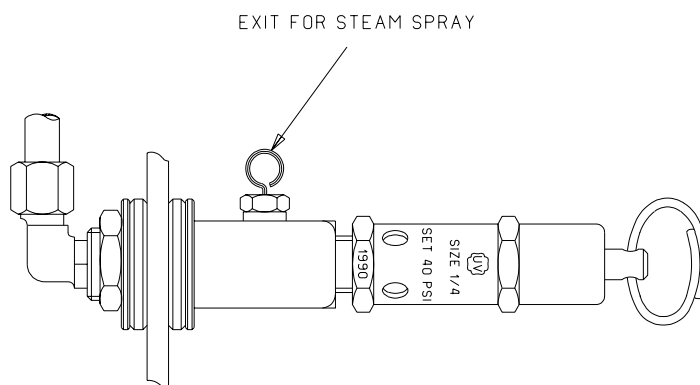

Caution:

Daily before operation, check the water level in the reservoir and add water when required. Once a week or after 20 cycles (the shorter period) replace the water in the reservoir.

4. Insert the plug into the socket at the rear of the autoclave.
5. Insert the plug into the electrical source.
6. Turn the main switch to START position.

- Set the multi-purpose valve knob to the FILL position. The water will now flow into the chamber. When the water reaches the mark at the bottom of the autoclave set the multi-purpose valve knob to the STE.(sterilize) position.

Note: When used for the first time, the multi-purpose valve requires slight effort, but with use it will turn smoothly and easily.



Warning

Multi-purpose valve knob should be turned in a clock-wise direction only!

- Load the autoclave.

Note: Using the drums is not recommended.

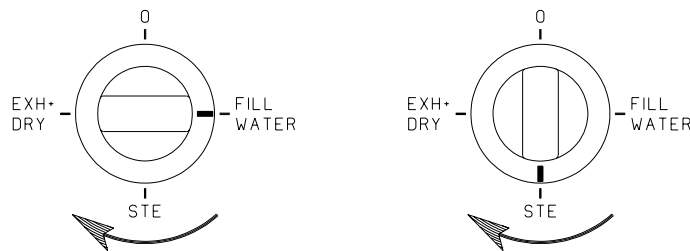

- Shut the door and move the door tightening bolt handle clockwise until it is closed tightly.

Note:

Due to inherent elasticity of the door gasket, the HEAT indicator light may indicate that the door is closed before a complete seal is made between the door and the chamber.

Therefore, in order to ensure the door is fully sealed, continue to tighten the door bolt until “hand-tight”. Do not over - tighten the bolt as this may result in damage to the gasket.

- Turn the pressure switch (B10) knob to the desired sterilization temperature.

230°F-273°F (110°C-134°C) 0-32Psi (1-2.1Bar)

This autoclave is designed according to all international standards, which allows the temperature to raise 4°F (2°C) over the working temperature.

If this discrepancy effects your working procedures, you may decrease the working temperature by turning the pressure switch (B10) knob slightly counter clock-wise.

Caution:



VERY IMPORTANT!

The Temperature scale on the panel is very accurate, however due to sensitivity of the pressure switch (B10), slight differences may occur. An adjustment of the pressure switch (B10) knob may have to be made upon initial installation, so that the pressure gauge shows as follows:

**16 - 18psi for 250°F
30 - 32psi for 273°F**

**1.1 - 1.2 Bars for 121°C
2 - 2.1 Bars for 134°C**

11. Set the STE. timer to the desired sterilization period according to the Sterilization Time Table (see table ahead). Recommended times for a, b, c are based on tests performed with a load according to Sterilization Load Test Table:

Sterilization Load Test Table

<i>Models</i>	<i>Loads</i>	
	<i>kg</i>	<i>lbs</i>
1730	1.5	3.3
2340	3.2	7.0
2540	4.0	8.8
3545	5.0	11.0
3850	6.0	13.6
3870	8.0	17.5

Sterilization Time Table

<i>MATERIAL</i>	<i>STE. TEMP</i>	<i>TOTAL TIME</i> (from start to finish)		<i>MODELS</i>
		Cold Start	Hot Start	
a. Unwrapped instruments, open glass or metal containers and any other items where such temperature is suitable	273°F (134°C)	30min.	20min.	1730, 2340, 2540
		35min.	25min.	3545, 3850, 3870
Single Instruments				
b. Wrapped instruments, standard cassettes, rubber tubing and any other items where such temperature is suitable.	273°F (134°C)	40min.	30min.	1730, 2340, 2540
		45min.	35min.	3545, 3850, 3870
c. Packs and any other items where such temp. is suitable.	273°F (134°C)	45min.	35min.	all models
d. Liquids and any other items where such temp. is suitable	250°F (121°C)	60min.	50min.	all models

These recommended sterilization times are based on a voltage supply of 120V or 230V. If the voltage supplied is less than 120V or 230V, additional time must be added.

Temperature lower than 250°F (121°C) can be achieved by setting the pressure switch (B10) knob at the desired temperature.

12. The POWER light is lit during the entire sterilization period, indicating connection to the power. The HEAT indicator signifies the operation of the pressure switch (B10), which keeps the temperature stable by connecting and disconnecting the heating elements. When the timer reaches 0, the sterilization process is complete and a buzzer will indicate that the cycle is complete.
13. If a cycle with drying is required proceed according to para. 14.
If a cycle without drying is required proceed according to para. 15

14. Cycle with drying

- 14.1 When the pressure gauge reaches 0, release the locking device and open the door slightly, in order to permit the steam to evacuate
- 14.2 Set the timer on 20-30minutes. Drying indicator lamp will light.
- 14.3 When the time is over, turn the multi-purpose valve knob to "0" position.
- 14.4 Open the door and Remove the load.

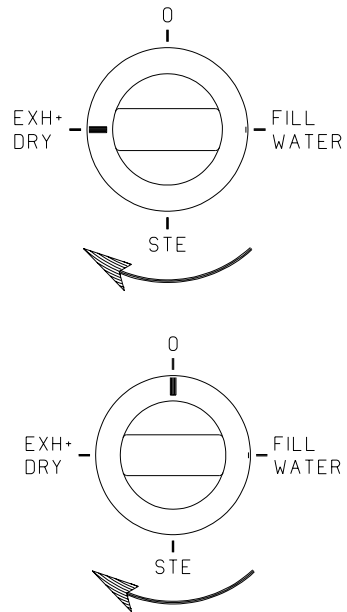

Warning



Multi-purpose valve knob should be turned in a clockwise direction only.

15. Cycle without drying

- 15.1 Turn immediately, the multi-purpose valve knob to EXH.+DRY (Exhaust and Dry) position.
- 15.2 When the pressure gauge reaches 0, turn the multi-purpose valve knob to "0"
- 15.3 Open the door to remove the load.

Warning



Multi-purpose valve knob should be turned in a clockwise direction only.

Note:



The sterility of instruments processed in unwrapped cycles cannot be maintained if exposed to a non-sterile environment.

16. Liquids

- 16.1 When sterilizing liquids, it is essential to leave the multi-purpose knob on sterilization position after the sterilization cycle is over, letting the steam escape slowly.
- 16.2 It is recommended to put the bottles on an un-perforated tray, which can be ordered at Tuttnauer, to prevent the clogging of the vessel opening in case the liquid starts boiling.
- 16.3 When the pressure decreases to “0” open the door and unload the autoclave.
- 16.4 Turn the multi-purpose valve knob to 0.



Warning

Multi-purpose valve knob should be turned in a clock-wise direction only.



Caution

If the door handle cannot be turned counter-clockwise for the door to be opened, the reason may be that the pin is set firmly in the groove. In order to release the pin, slightly turn the handle in the closing direction (clockwise). The pin is released, enabling the operator to open the door. In case the door still cannot be opened, refer to the instructions in the chapter “Pressure Door Lock System” (para. 11.11).

NOTE:

After operating the sterilizer, brown stains might appear on the bottom of the chamber. These stains are a result of the heating elements that are located at the lower external part of the chamber. The brown color is a common phenomenon, can be easily be removed, and will not have any effect on the sterilized goods.

At the end of the working day turn the main switch to "STOP" position.

8. MAINTENANCE INSTRUCTIONS

8.1 Preventive and Scheduled Maintenance

The maintenance operations described in this chapter have to be fulfilled periodically, to keep the autoclave in good condition and to reduce the breakdown time to a minimum. These operations can easily be executed by the users maintenance personnel, according to the instructions provided ahead.

8.1.1 Daily

Clean the door gasket with a soft cloth or a sponge.



Caution

Before starting, ensure the electric cord is disconnected and there is no pressure in the autoclave.

8.1.2 Weekly

1. Take out the tray holder and trays. Clean the tray holder and trays with a cleaning agent & water and with a cloth sponge. You may use diluted lemon acid (25-50 CC lemon acid in 1 liter of water) as cleaning agent. If detergent is used, rinse the tray holder and trays immediately with water to avoid stains on the metal.



Do not use steel wool or steel brush as this may damage the chamber!

2. Once a week clean and descale the chamber, copper tubes and the reservoir using 'Chamber Brite™'.
3. Put a few drops of oil on the 2 door pins and door tightening bolts.
4. Clean the outer parts of the autoclave with a soft cloth.
5. Once a week drain the water from the reservoir, and pour fresh mineral-free water or distilled water; refer to recommendations of water quality – para. 5.

8.1.3 Periodical tests

1. Once every month check the safety valve - refer to para. 8.4.
2. Once every month check the air trap jet - refer to para. 11.2.
3. Check the door gasket every 12 months and replace it if required (see para. 8.3).
4. Once a year check and tighten the piping joints to prevent leakage.
5. Once a year check and tighten all screw connections in the control box, heaters and valves and instrumentation. This must be done by a qualified electrician.
6. Once a year calibrate the pressure switch (B10).
7. Every 5 years test the locking device for excessive wear.
8. Perform safety tests according to local rules and regulations.

Recommendation

For OPTIMAL cleaning and de-scaling, use Tuttnauer's powdered cleaner, 'Chamber Brite™' which is user friendly and has excellent results.

8.2 *Draining the Reservoir*

1. Turn the drain valve counter-clockwise (1 turn) to drain the water.
2. Turn the drain valve clockwise to CLOSE position.
3. Fill the reservoir with distilled or mineral-free water up to the base of the safety valve holder.
4. Connect the electric cord to the power source.

The autoclave is ready for use:

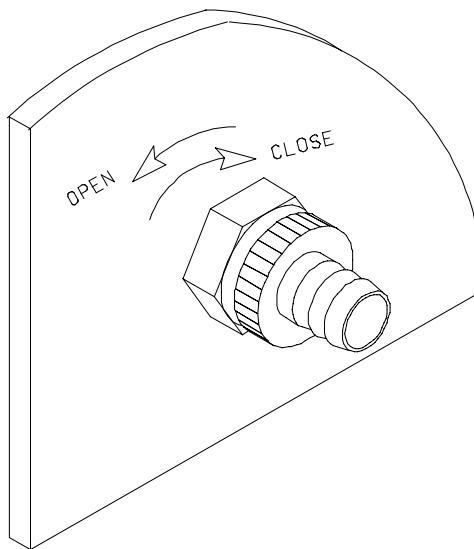

8.3 Replacing the Door Gasket

Pull off the gasket from the door groove, thereby installing the new gasket referring to the drawings above 1, 2 and 3.

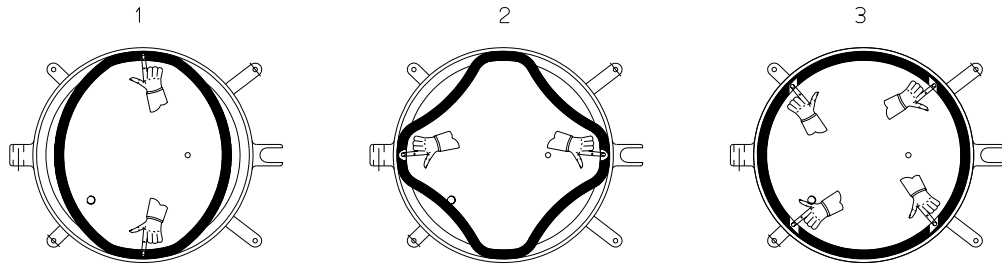

Caution!

This gasket is designed with a trapezoidal cross section. The gasket should be placed with the widest side towards the door.

8.4 *Checking the Safety Valve* (Located in the water reservoir.)

In order to prevent the safety valve from blockage, every two months, under ordinary usage, it is necessary to allow the steam pressure to escape through it.

Checking the safety valve shall be performed during any cycle, when the pressure in the chamber is approx. 200 kPa (29 psi).

1. Remove the water reservoir cover.
2. Pull the ring of the safety valve using a tool (screwdriver, hook etc.) and open the safety valve for 2 seconds. Be careful not to burn your hands.
3. Verify that the valve releases steam and closes immediately.
4. If the safety valve is stuck in the ‘open’ position, stop the operation of the autoclave and let the pressure decrease to zero (atmospheric pressure).
5. After the pressure in the chamber decrease to zero, pull the valve ring and release the valve.
6. Repeat operations 1 to 3.
7. If the valve is stuck again in open position, call for service.

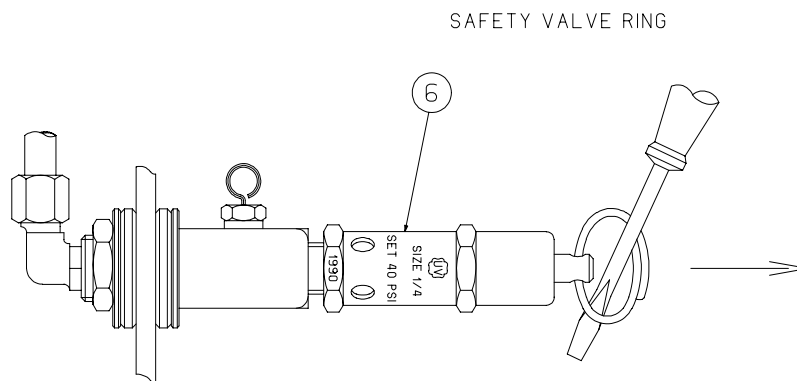

9. **CLEANING TABLE TOP AUTOCLAVES WITH CHAMBER BRITE™**

CHAMBER BRITE™ is a cleaning and descaling agent designed specifically for the cleaning and removal of water deposits, oxides and other sediments that are found in steam sterilizers. The material is a combination of acidic salts and additional cleaning materials.

Cleaning Procedure

1. Important – all steps in this procedure must be completed without interruption.
2. When the autoclave chamber is cold, remove instruments and trays from the autoclave.
3. Open the door and spread the contents of a packet in a straight even line along the bottom of the chamber, from back to front.
4. Start a sterilization cycle* with water and No Drying Cycle according to the manufacturers instructions. When the cycle is finished exhaust the unit.
5. At the end of the exhaust cycle drain the water the reservoir.
6. Fill the water reservoir with distilled water.
7. Repeat a sterilization cycle without Chamber Brite™ powder, to remove any excessive dirt in the pipes. Start a sterilization cycle* with water and No Drying Cycle according to the manufacturers instructions. When the cycle is finished exhaust the unit
8. At the end of the exhaust cycle drain the water from the reservoir.
9. Turn the autoclave off and allow chamber to cool.
10. Remove the tray holder; wipe the interior of the chamber with a damp cloth.
11. Fill the reservoir with distilled water or mineral free water only.
12. Wipe the tray holder with a damp cloth and return it to the chamber.
13. Turn fill knob to fill position and allow a small amount of water (2-4 ounces) to fill chamber. Remove water from chamber.
14. The instrument is ready to use.



IMPORTANT:

DO NOT sterilize instruments during the cleaning process!!!

CAUTION:

Keep out of reach of children. Contains mildly acidic ingredients. Avoid contact with the skin, eyes or clothing. Wash hands well after touching the powder, in the case of eye contact flush with continuous running water for at least 15 minutes. If irritation persists get medical attention. If accidentally swallowed, do not induce vomiting, drink large amounts of water and obtain medical attention. MSDS available upon request.

For models 1730, 2340, 2540 use one packet of CHAMBER BRITE™.

For models 3545, 3850, 3870 use two packets of CHAMBER BRITE™.

Clean every 20 cycles or as needed.

* Total cycle time for cleaning Tuttnauer “M” series is 30 minutes at 273°F (134°C). All cycles referenced are from a cold start.

SERVICE AND MAINTENANCE SECTION



Caution:

These servicing instructions are for use by qualified personnel only. To avoid electric shock, do not perform any servicing other than that contained in the operating instructions unless you are qualified to do so.

Refer all servicing to qualified service personnel.

10. TROUBLESHOOTING

<i>Symptom</i>	<i>Possible Cause</i>	<i>Correction</i>
<p>1. Multi-purpose valve is in FILL position.</p> <p>Water does not enter into the chamber.</p>	<p>1.1 No water in the reservoir.</p> <p>1.2 Multi-purpose valve of chamber is clogged.</p> <p>1.3 The pipe is clogged.</p>	<p>1.1 Fill the reservoir with mineral-free water.</p> <p>1.2 Follow instructions in para. 11.10.</p> <p>1.3 Follow instructions in para. 11.10.</p>
<p>2. While main switch is in START position POWER indicator light does not light up.</p>	<p>2.1 No power supply.</p> <p>2.2 Circuit breaker tripped.</p> <p>2.3 Main Switch is defective.</p> <p>2.4 Set timer for 15 minutes. Turn the multi-purpose valve to "DRY" position. If "HEAT" & "DRY" lights are on then "POWER" bulb is burnt.</p> <p>2.5 If also "HEAT" & "DRY" lights are not on then the electrical line is faulty.</p>	<p>2.1 Restore power supply.</p> <p>2.2 Lift the lever of the circuit breaker.</p> <p>2.3 Check and replace it if necessary.</p> <p>2.4 Replace "POWER" bulb.</p> <p>2.5 Check and repair the line from the entry until the main switch.</p>
<p>3. Multi-purpose valve is in STE. position, main switch in ON position. Timer and pressure switch (B10) are in any working position and the door is closed tightly.</p> <p>3.1 "HEAT" light is not on but the autoclave operates</p> <p>3.2 "HEAT" light is not on and heating is insufficient</p> <p>3.3 "HEAT" light is not on and there is no heating.</p>	<p>3.1.1 Burnt bulb.</p> <p>3.2.1 Pressure switch (B10) set to too low temperature</p> <p>3.2.2 Microswitch No.2 is faulty.</p> <p>3.2.3 Bridge No. 10 is faulty.</p> <p>3.3.1 Pressure switch (B10) is faulty.</p> <p>3.3.2 Safety thermostat</p>	<p>3.1.1 Replace faulty bulb.</p> <p>3.2.1 Adjust the pressure switch (B10).</p> <p>3.2.2 Replace the faulty Microswitch.</p> <p>3.2.3 Fix the bridge.</p> <p>3.3.1 Fix or replace the faulty pressure switch (B10).</p> <p>3.3.2 Fix or replace the</p>

	faulty.	faulty thermostat.
<i>Symptom</i>	<i>Possible Cause</i>	<i>Correction</i>
3.3 "HEAT" light is not on and there is no heating. (cont.)	3.3.3 Timer is faulty. 3.3.4 Microswitch No.3 is faulty. 3.3.5 Pressure switch (B10) is faulty. 3.3.6 Door switch is faulty.	3.3.3 Fix or replace the faulty timer. 3.3.4 Fix or replace the faulty microswitch. 3.3.5 Fix or replace the faulty pressure switch (B10). 3.3.6 Fix or replace the faulty door switch.
4. Multi-purpose valve on STE. position. POWER and HEAT indicator lights are lit. Temperature and pressure are not sufficient.	4.1 Water level is lower than required. 4.2 Pressure switch (B10) (B10) is not calibrated. 4.3 Steam escapes from safety valve. 4.4 Air trap jet hole leaks excessively. 4.5 Steam escapes from the door seal. 4.6 Steam escapes from piping connections.	4.1 Add water per para. 4. 4.2 Calibrate the pressure switch (B10). 4.3 Pull safety valve ring for 2 seconds, then release. If leakage continues, replace it. 4.4 Replace the air trap jet. 4.5 Tighten door locking bolt. If leakage persists, replace door seal. 4.6 Locate leakage and repair faulty piping connection.
5. Pressure builds up very slowly.	5.1 One or more heaters are burnt. 5.2 Too much water in the chamber. 5.3 Door gasket leakage. 5.4 Safety thermostat is not set to the right temp (stops heating in the "increase pressure" stage).	5.1 Check and replace heaters if necessary. 5.2 Check if chamber holds the correct amount of water (para. 4). 5.3 Tighten a bit more, if leakage continues, replace gasket. 5.4 Calibrate the thermostat.

<i>Symptom</i>	<i>Possible Cause</i>	<i>Correction</i>
6. Temperature safety device is activated during the ste. cycles due to overheating.	6.1 Amount of water in chamber is insufficient. 6.2 The thermostat is not set to the right temperature. 6.3 Multi-purpose valve is leaking. Water returns to water reservoir. 6.4 Safety valve is leaking. 6.5 Air trap jet leaks excessively.	6.1 Add water per para. 4. 6.2 Set the thermostat to the right temperature. 6.3 Replace the valve (see para. 11.9). 6.4 Replace the safety valve (see para. 11.3). 6.5 Replace air jet (see para. 11.2)
7. Autoclave in STE. position. Pressure safety valve is activated and heating continues.	7.1 Faulty pressure switch (B10) does not stop heating when reaching required temp. 7.2 Pressure safety valve is faulty.	7.1 Fix or replace the pressure switch (B10). 7.2 Replace the Pressure safety valve.
8. Dry operation does not work.	8.1 Dry microswitch MSw2 not actuated or faulty. 8.2 Timer board faulty.	8.1 Replace microswitch. 8.2 Replace timer board.
9. Door handle cannot be turned counter clockwise for opening.	9.1 Door pin set in groove. 9.2 Door locking system stuck or bellows damaged.	9.1 Slightly turn handle in closing direction (clockwise), then attempt to open. 9.2 If problem persists, refer to "Pressure Door Lock System" in the service section. After opening the door, replace the bellows.

11. MAINTAINING AND REPLACING PARTS

11.1 Safety Tests after Repair



ATTENTION!

After every repair or dismantling the enclosure, the autoclave should pass two safety electrical test by the Service Engineer. The following shall be performed:

1. Enclosure Leakage Current Test.

Every autoclave should pass this test as follows:

1. Connect the electrical cord to the autoclave.
2. Turn on the main switch and the circuit breaker.
3. Short-circuit the L and N pins on the cord's plug.
4. Connect the Short-circuit pins to the L pole on the Megger.
5. Connect the earth pins to the earth pole on the Megger.
6. Impose an electrical potential of 500-1000V on the tested autoclave. The insulation resistance should be at least 2 M Ω .
The test is successful if there was no leakage.

2. Protective Earth Impedance Test

1. Connect the grounding pin of the power cord plug to one pole of an Ohmmeter.
2. Connect any other metallic part (preferable – the metallic part of the locking screw) to the second pole of the Ohmmeter.
3. The resistance should not exceed 0.3 Ω .

After performing these tests, the Service Engineer should complete and sign the Work Order.

11.2 Dismantling the Outer Cover of the Autoclave.



Caution:

Allow the instrument to cool before removing the outer covers.

Warning:

Before starting disconnect the instrument from the power source and make sure there is no pressure in the autoclave.

Then proceed as follows:

1. Remove the screws holding the rear cover (1).
2. Remove the screws holding the cover to the base (2).
3. Pull the cover upwards.

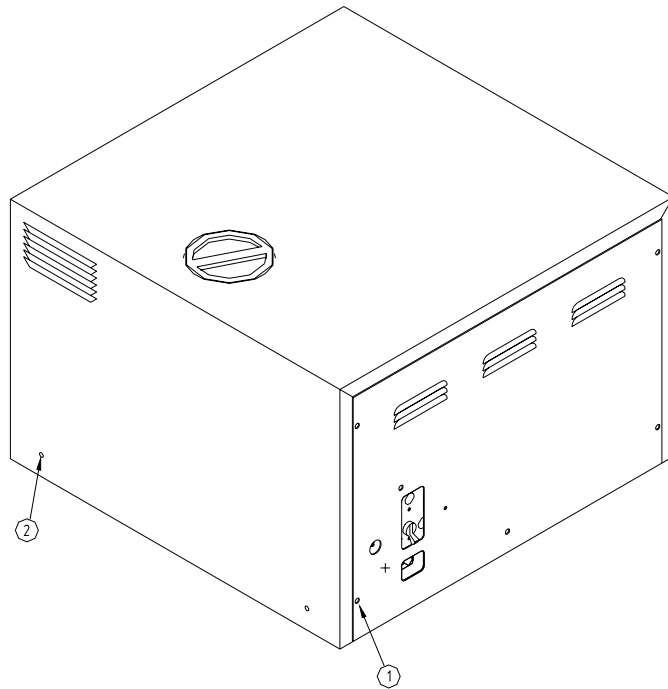

11.3 *Cleaning and Replacing Air Trap Jet*

(Located in the water reservoir)

The elimination of air pockets from the sterilization chamber during heating and sterilization phases is achieved by means of the air trap jet.

This device consists of a small orifice that is obtrusive and opened by a small wire moving forth and back.

The air pockets and small steam quantities are pushed up by the steam pressure and evacuated through this orifice.

Caution:



Before starting, ensure that the electric cord is disconnected and that there is no pressure in the autoclave.

1. Remove the water reservoir cover.
2. Clean the hole of the jet by manipulating the air trap wire back and forth (A).
3. In case it is necessary to replace the air trap jet, allow the instrument to cool and the pressure to drop to 0 before removing the jet.

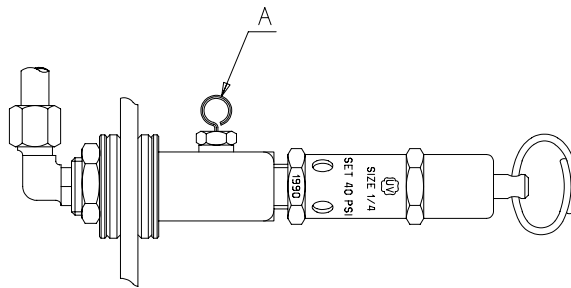

It is important to clean the hole of the air trap, as described at point 2 before starting operation of the autoclave, for the first time.

11.4 *Replacing the Safety Valve*

Caution



Before starting, be sure that the electric cord is disconnected and that there is no pressure in the autoclave.

1. Remove the water reservoir cover.
2. Unscrew the safety valve and remove it from the safety valve base.
3. Replace it with a new safety valve (ensure the safety valve is an original one!)
4. Test all autoclave.

11.5 Replacing the circuit breaker



Caution!

Before starting, disconnect the instrument from the power source.

1. Remove the autoclave cover (see para. 11.2 “Dismantling the Outer Covers of the Autoclave”).
2. Disconnect the wires from the circuit breaker.
3. Remove the four screws connecting the circuit breaker to the panel (1).
4. Replace the circuit breaker with a new one.
5. Reconnect the electrical wires.
6. Reassemble the cover.
7. Turn on the autoclave and verify it operates correctly.
8. Move the circuit breaker’s lever to the “tripped” position and verify that the autoclave turns off.



Make sure that the correct circuit breaker is installed as marked in the table below!

<i>Description</i>	1730		2340/2540		3545	3850/3870
	120V	230V	120V	230V	230V	230V
<i>Circuit breaker</i>	15A	10A	15A	10A	10A	15A

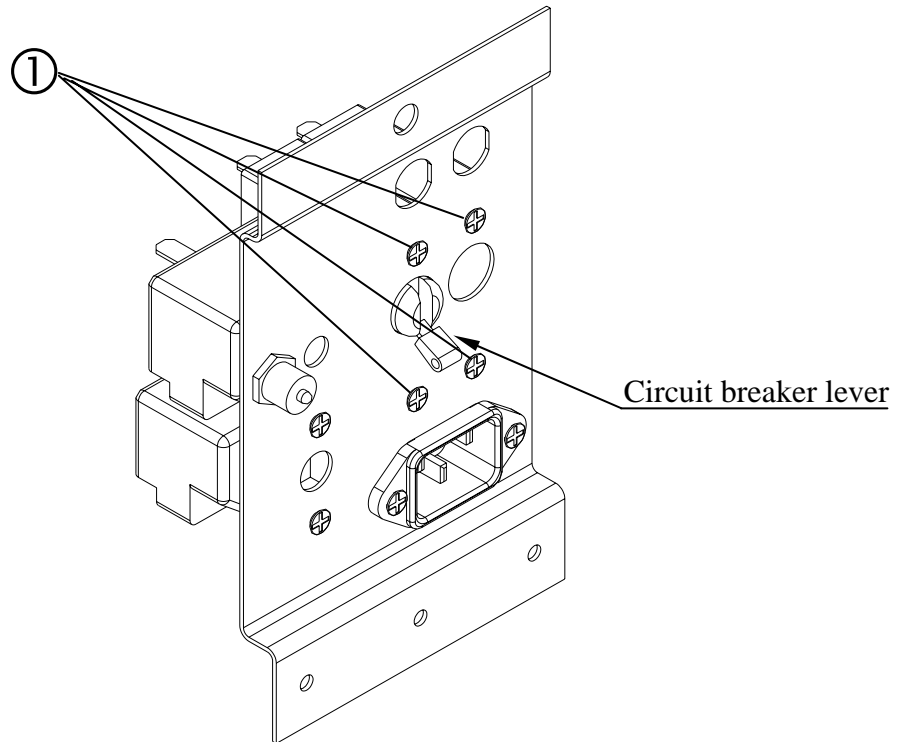

11.6 *Temperature Safety Thermostat* (Located on the rear side of the heaters)

The autoclave is supplied with a temperature thermostat that maintains the temperature during the dry stage, by connecting and disconnecting the electric power.

This device automatically disconnects the heating elements in case of a rise in temperature.

The electric power is automatically reconnected when the chamber cools down.

- ◆ To replace this safety thermostat, remove the rear cover, unscrew the thermostat and replace it.

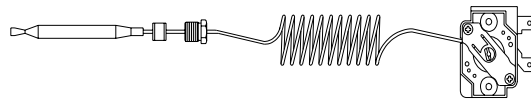

11.7 *Raising the Working the Temperature of the Safety Thermostat*



Caution:

Only authorized technician should do this operation!

1. Unscrew the rear cover of the autoclave.
2. With a screwdriver, turn the central screw slightly clockwise to raise the temperature.
3. Replace the rear cover.

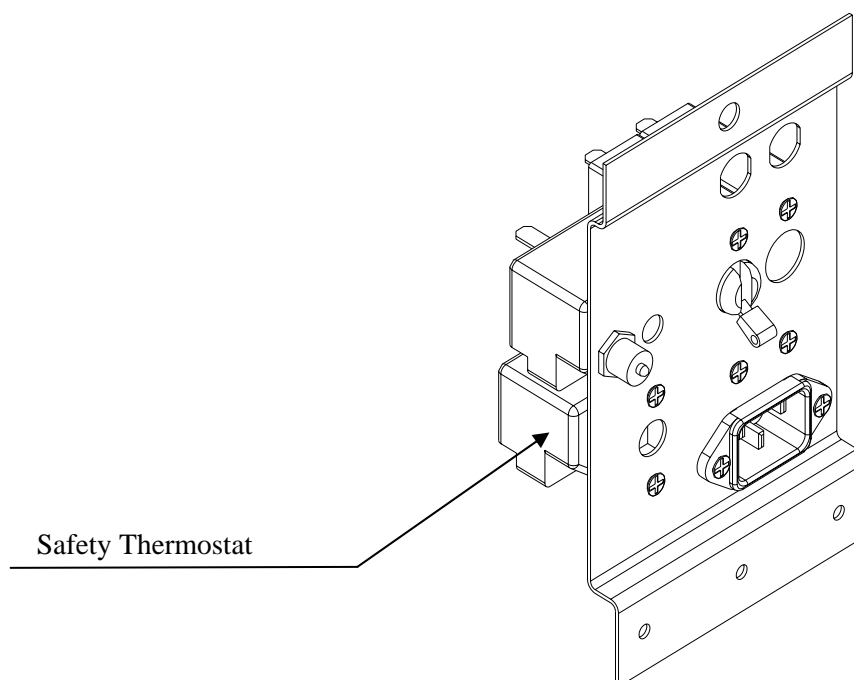

11.8 Cut-Off Thermostat

This thermostat cuts out power to the autoclave, in the event that all other safety systems do not function. For example: if the operator forgets to fill the chamber with water, and starts the sterilization cycle, the chamber will heat up and activate the cut-off thermostat. In order to restart the operation, press the RESET button. If the autoclave is operated according to the instructions, and the thermostat cuts off, a technician should be called.

The thermostat has been calibrated by the manufacturer of the autoclave. **Do not attempt to re-calibrate it**

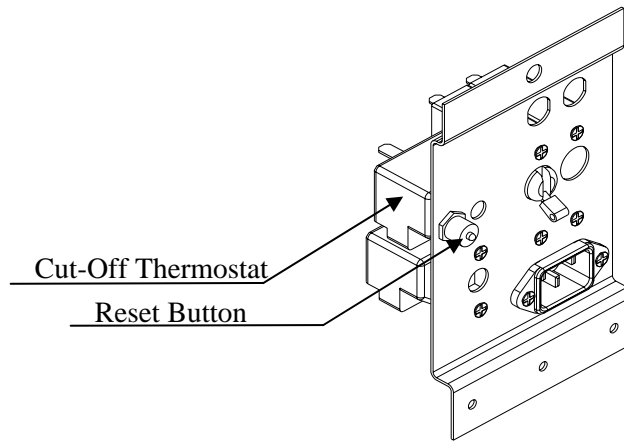

11.9 Replacing Heating Elements



Caution:

Before starting, ensure that the electric cord is disconnected from the power source and there is no pressure in the autoclave chamber.

1. Dismantle the autoclave cover (see para. 11.2 “Dismantling the Outer Covers of the Autoclave”).
2. Release the two terminal wires from the heating element.
3. Remove the heater tightening bolts (1).
4. Replace the damaged heating element with a new one and reconnect the two terminal wires.
5. Re-assemble the autoclave cover.
6. Test all the autoclave cycles.

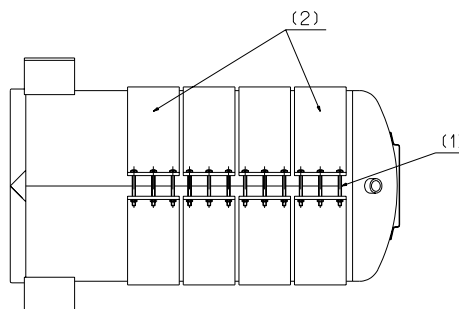

11.10 Replacing Multi-Purpose Valve



Caution:

Before starting, make sure that the electric cord is disconnected from the power source and there is no pressure in the autoclave chamber.

1. Dismantle the autoclave cover (see para. 11.2 “Dismantling the Outer Covers of the Autoclave”).
2. Drain the water from the water reservoir.
3. Pull the valve knob out.
4. Unscrew the 3 nuts that tighten the copper tubes to the multi-purpose valve.
5. Unscrew the nut holding the valve to its base.
6. Pull out the valve.
7. Replace it with a new one. Make sure that the valve is tightened to the valve base.
8. Reconnect the three tube nuts.
9. Return the valve knob to its place.
10. Turn the valve knob to FILL position.
11. Pour water into the reservoir.
12. Check the copper tube connections for leakage.
13. Replace the cover and tighten it to the base.

Occasionally, it is necessary to take off the screws that are on the shaft of the valve in order to take the valve out of its base.

After installing the new valve, the screws should be replaced according to the sketch on page 47.

11.11 Unclogging the multi-Purpose Valve or Chamber



VERY IMPORTANT!

When sterilizing cotton wool or pads, it is essential to wrap them in paper or cotton bags in order to prevent the multi-purpose valve and the autoclave openings from becoming clogged with remnants of the material.

1. Pour distilled water into the chamber, according to quantities mentioned in para. 4 (*Installation, Placing and Leveling Instructions*).
2. Close the door.
3. Turn the multi-purpose valve to STE. position.
4. Turn the timer knob to 20 min.
5. Turn the pressure switch (B10) knob to either 250 or 274°F (121 to 134°C).
6. Turn the main switch to START position.
7. After the timer has reached “0” turn the multi-purpose valve (clockwise) to the FILL position.

In most cases, the pressure pushes the obstructing substance out, and the steam exhausts into the water reservoir.

8. When the pressure gauge reaches 0, turn the multi-purpose valve to the OFF position, and the main switch to STOP.
9. Open the door.
10. Replace the water in the water reservoir.

The autoclave is ready for the next cycle.

11. If this procedure does not clear up the clogging, replace the multi-purpose valve.

11.12 Pressure Door Lock System

This safety device prevents the door from opening when the chamber is pressurized.

The system is based on the built up pressure in the chamber that pushes the Silicon-rubber bellows and the pin into the groove of the tightening bolt. This prevents the operator from opening the door. When the steam is released, this bellow returns to its original position, drawing the pin with it thus releasing the tightening bolt.

Should there be no pressure in the chamber, and the door cannot be opened, the following procedure should be observed.

1. Turn the handle of the multi-purpose valve to EXH. & DRY.
2. The steam exhaust valve pipe is open and air inserts the chamber. In this stage the door can be opened.

11.13 Replacing the Door Bellows

(Located in the Door Bridge)



Caution:

Before starting, be sure that there is no pressure in the autoclave chamber.

1. Open the door.
2. Unscrew and remove the tightening screw (5).
3. Gently pull out the door safety device locking pin (13).
4. It is possible that the washers (7, 10) will be stuck - if so, push them out by introducing pressurized air through the steam inlet hole.
5. Reconnect the door device locking pin (13) into a new silicone bellows (12).
6. Put the silicone bellows (12) and pin (13) into the bellows housing (14) and replace the washers (7,10).
7. Reconnect all the above into the door bridge.
8. Re-screw and tighten the tightening screw (5).
9. Test all autoclave cycles.

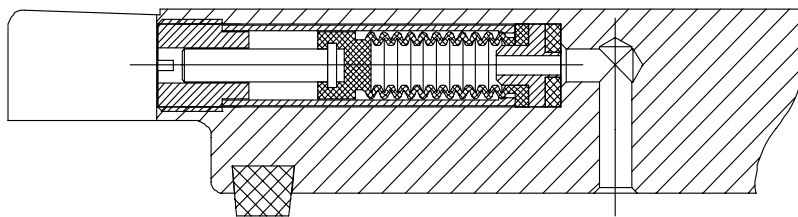
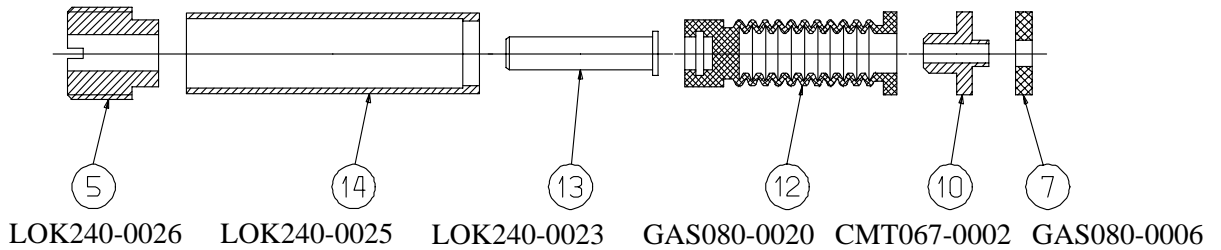

11.14 Replacing the pressure switch B10



Caution:

Before starting, be sure that the electric cord is disconnected from the power source and that there is no pressure in the autoclave chamber.

1. Remove the autoclave cover (see para. 11.2 “Dismantling the Outer Covers of the Autoclave”).
2. Unscrew the nut (1) connecting the pressure pipe (the pipe connecting the pressure switch to the chamber).
3. Remove the isolating cover.
4. Remove the pressure switch knob.
5. Unscrew the 2 screws connecting the pressure switch to the panel (located under the pressure switch knob).
6. Unscrew the nuts connecting the wires to the pressure switch (2).
7. Remove the pressure switch and replace it with a new one.
8. Reconnect the electrical wires.
9. Reassemble the pressure switch to the panel.
10. Reassemble the knob and the pressure pipe.
11. Re-assemble the isolating and the autoclave cover.
12. Test and calibrate the pressure switch.
13. Test all the autoclave cycles and verify it operates correctly.



11.15 Replacement of the Door Cover



Caution:

Before starting, be sure that the electric cord is disconnected from the power source and that there is no pressure in the autoclave chamber.

1. Unscrew the four screws attaching the door cover and remove the door cover. Since the screw pressing the door microswitch includes two washers and a spring, be aware not to lose them.
2. Reassemble the new cover.
3. Insert screw (1) until dimension A is approximately 15 mm.
 - 3.1 Please note that on model 3140 two washers (2) are placed between the spring (4) and the door.
4. Perform final adjustment of the screw as follows:
 - 4.1 While the autoclave is disconnected from electricity turn on the circuit breaker.
 - 4.2 Connect the electrical plug to a multi-meter.
 - 4.3 Press the microswitch and verify that the microswitch functions as required.
 - 4.4 Close the door and verify that the microswitch operates.
 - 4.5 If the microswitch does not operate unscrew the screw one turn counter-clockwise and check per para. 4.4. Repeat until microswitch operates.
 - 4.6 Connect the autoclave to electricity.
 - 4.7 Close the door until the microswitch indicates that the door is closed. Operate the autoclave and verify that there is no steam or pressure leak.
 - 4.8 If there is steam leak, stop the autoclave's operation, reduce steam pressure, open the door and turn the screw one turn clockwise and check per para. 4.7. Repeat until leakage ceases.

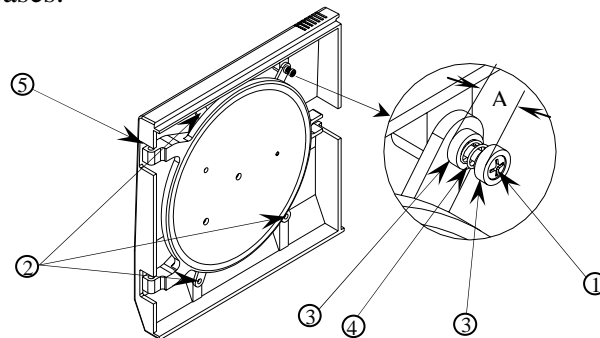

No.	Description	Model	Cat. No.	No.	Description	Model	Cat. No.
1	Screw	2340, 2540	BOL191-0032	3	Washer	All models	ELE036-0009
		1730, 3545, 3850, 3870	BOL191-0091	4	Spring	All models	SPR177-0012
2	Screw	2340, 2540	BOL191-0033	5	Door cover	1730	POL065-0001
		3545	BOL191-0115			2340, 2540	POL066-0002
		1730, 3850, 3870	BOL191-0140			3545	COV314-0001
						3850, 3870	POL065-0004

11.16 Replacing the Locking Device

Caution:



Before starting, verify that there is no pressure in the autoclave chamber.

1. Remove the security ring (9) using a special tool.
2. Remove pin (6).
3. Remove locking device. Take care not to lose the Teflon disk (10).
4. Reassemble the new locking device.
5. Insert the pin (6).
6. Reassemble the security ring (9).

CLOSING DEVICE

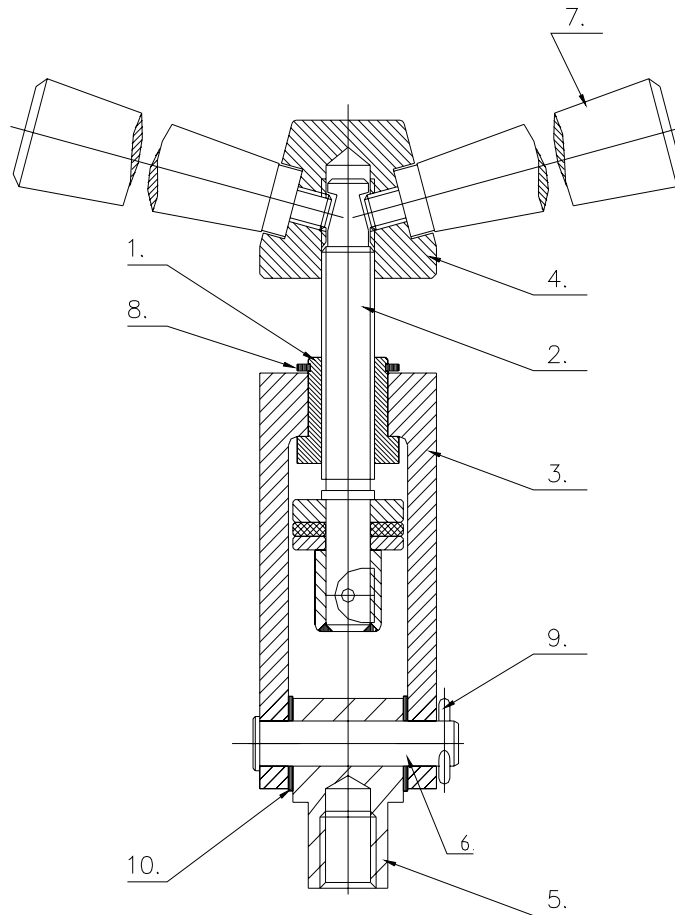

No.	Description	No.	Description
1	Bushing	6	Door locking device pin
2	Door tightening bolt assembly	7	Bakelite handle
3	Locking screw housing	8	Closing bridge "c" clip
4	Locking base	9	Cotter pin
5	Locking housing axis	10	Teflon disk

11.17 Replacing the Door Switch

Caution!



Before starting, disconnect the instrument from the power source and ensure that there is no pressure in the autoclave.

Allow the autoclave to cool before removing outer covers.

1. Remove the autoclave cover (see para. 11.2 “Dismantling the Outer Covers of the Autoclave”).
2. Disconnect the wires (1), (2) from the door switch (3).
3. Remove the microswitch and replace it with a new one.
4. Reconnect the wires the microswitch. Verify that the wire is placed on the isolating cover (4) and does not touch the chamber.
5. Reassemble the door cover.
6. Test the connection with an ohmmeter. In “open” position the ohmmeter shows disconnection and in “close” position the ohmmeter shows connection.

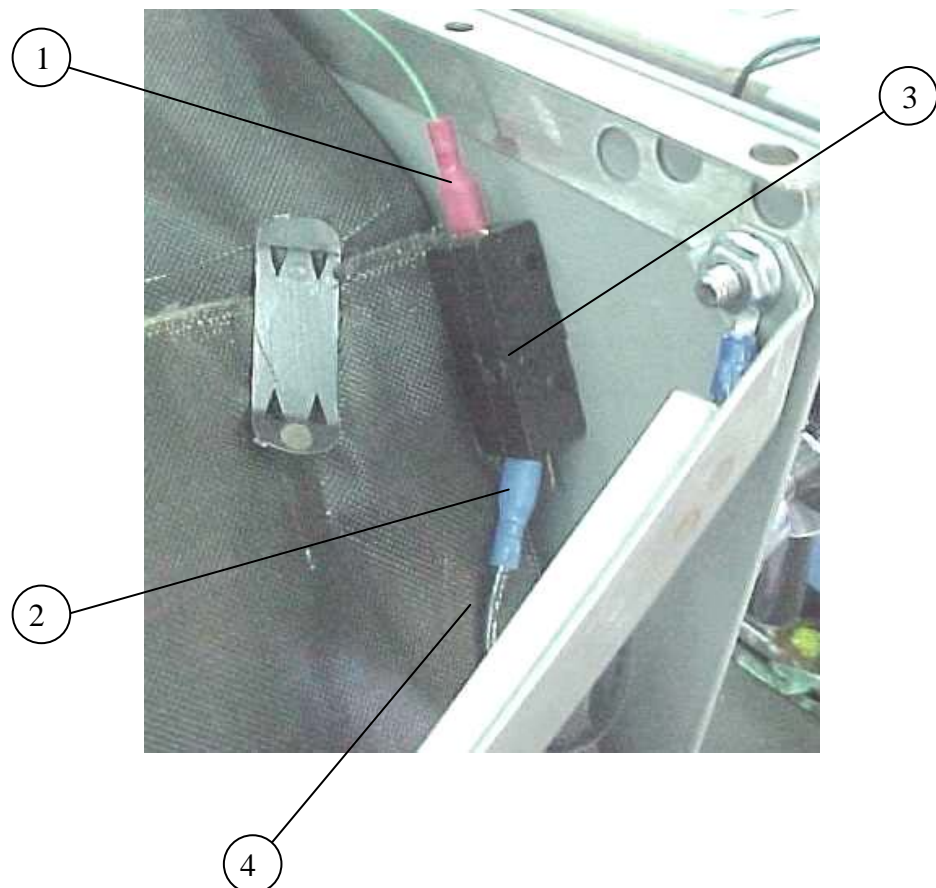

MULTI-PURPOSE VALVE ASSEMBLY CMT240-0027

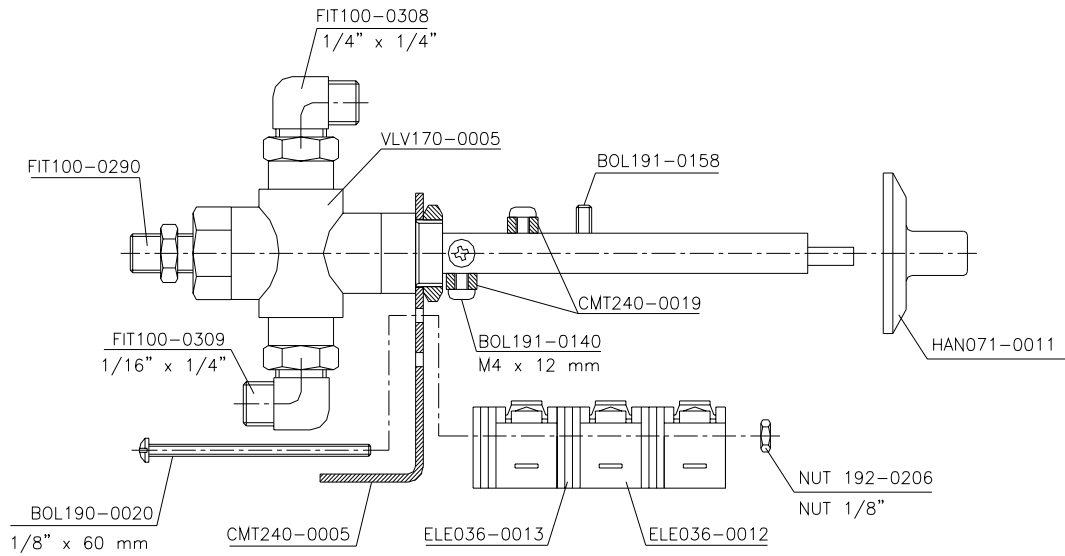

Position of Micro-Switches and their Operation Situation					
M.Sw	Stage	-0-	Fill	Ste.	Exh. + Dry
M.Sw.1		Tight	Tight	Loose	Loose
M.Sw.2		Loose	Loose	Loose	Tight
M.Sw.3		Loose	Loose	Loose	Tight

Notes:

1. Microswitches MSw1 - STER. and MSw. 2- DRY are actuated by the multi-purpose valve.
2. Microswitch MSw3 - Door Sw. is actuated by the door and is in pos. ON when the door is closed.

GENERAL VIEW OF VESSEL, DOOR AND ACCESSORIES

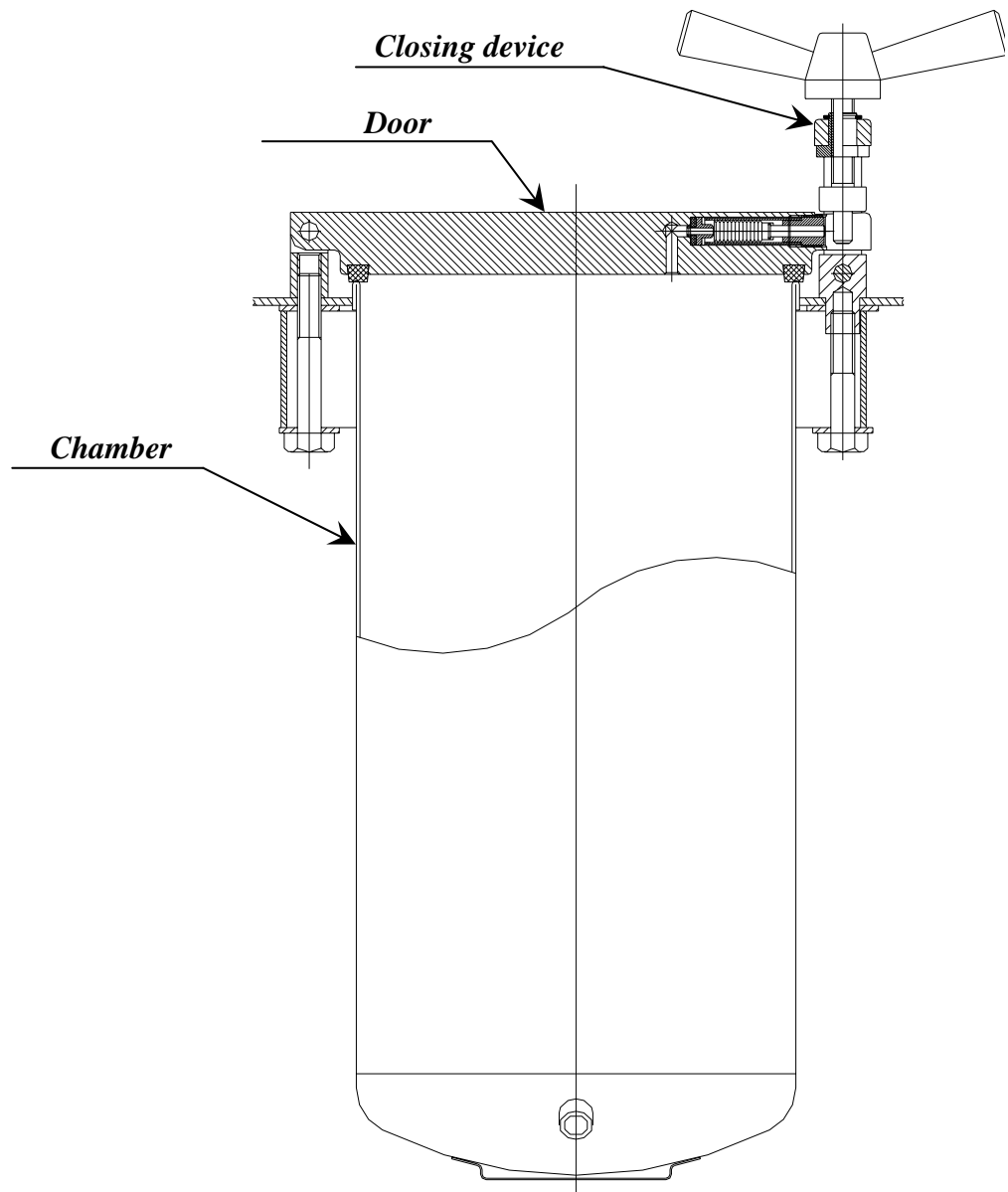

AUTOCLAVE COVER

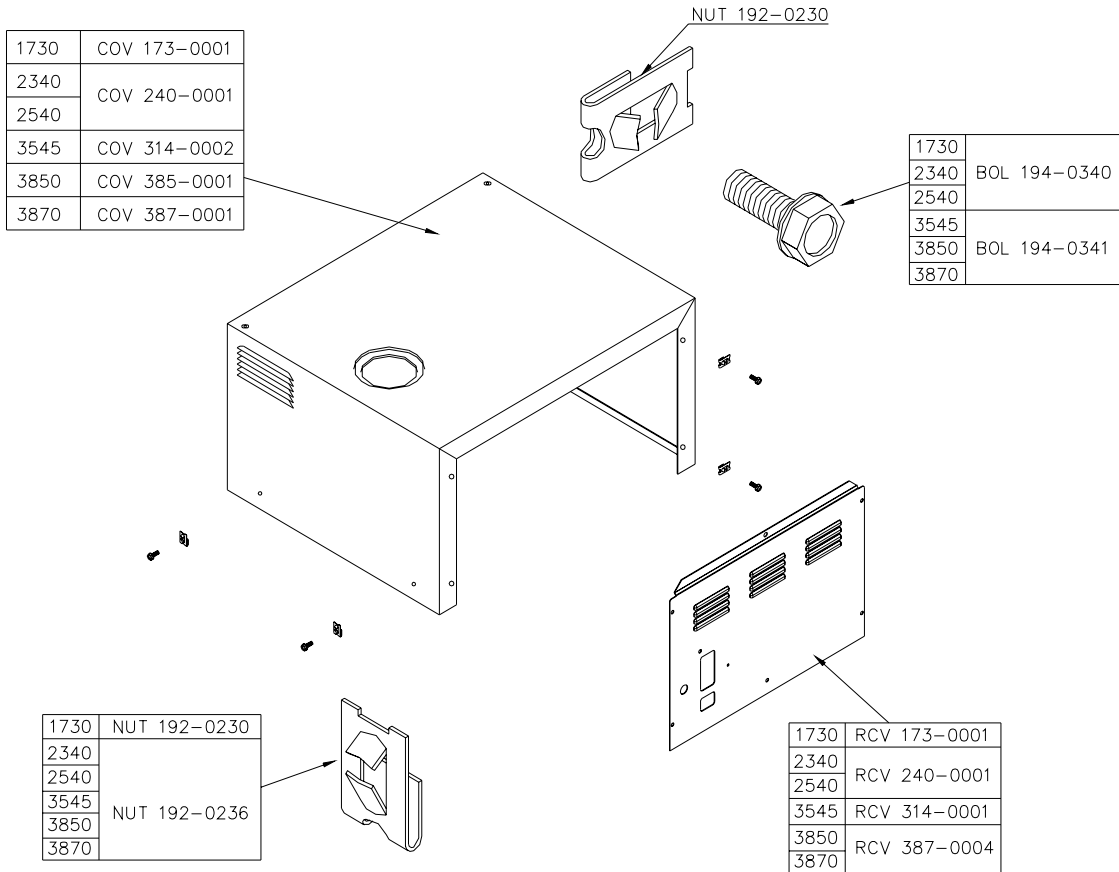

TRAY HANDLE CMT240-0001

For 1730, 2340, 2450 models only

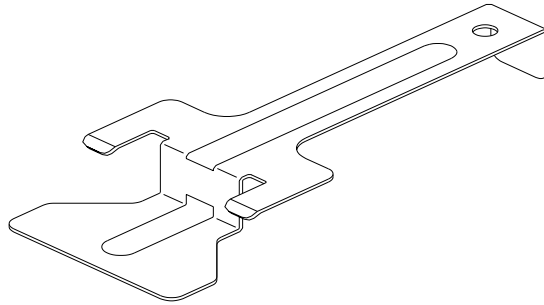

POUCH RACK

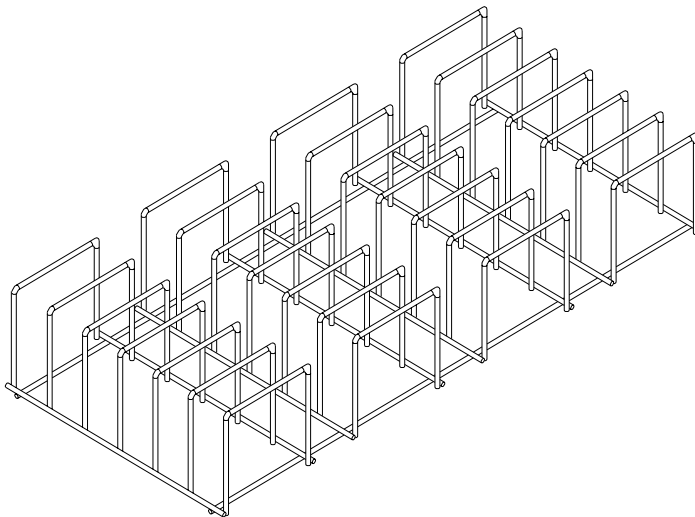

TYPE	CAT No.
2340	ACS215-0008
2540	
3870	ACS215-0010

TRAY

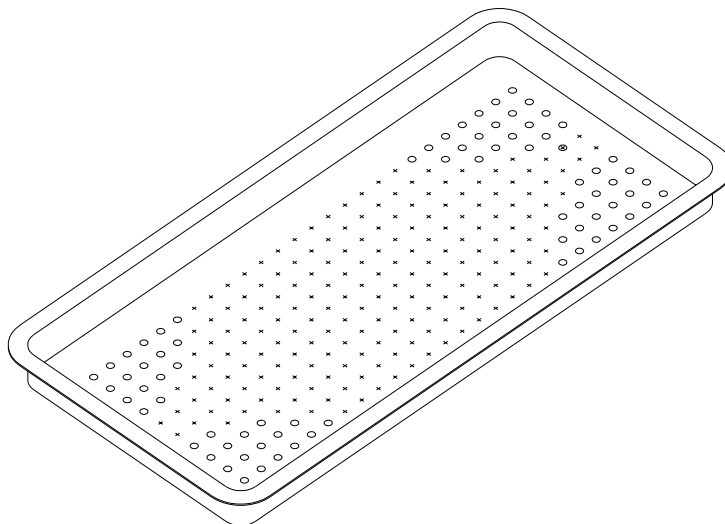

MODEL	SIZE	CAT. No.
1730		TRY173-0001
2340		TRY240-0001
2540		TRY240-0001
3545	Big	TRY314-0001
	Small	TRY314-0002
3850	Big	TRY385-0003
	Small	TRY385-0004
3870	Big	TRY387-0001
	Small	TRY387-0003

TRAY HOLDER

MODEL	TRAY HOLDER CAT. NO.
1730	TRH173-0001
2340	TRH234-0001
2540	TRH254-0001
3545	TRH314-0000
3850	TRH385-0001
3870	TRH387-0001

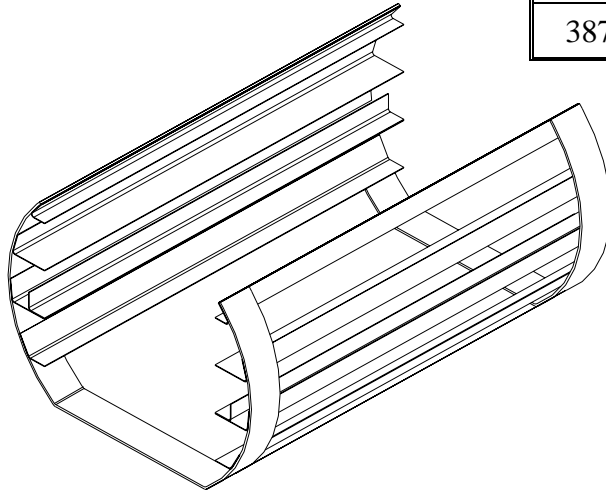

ALTERNATIVE TRAY HOLDER

These tray holders are designed for use in models 2340 & 2540 only.

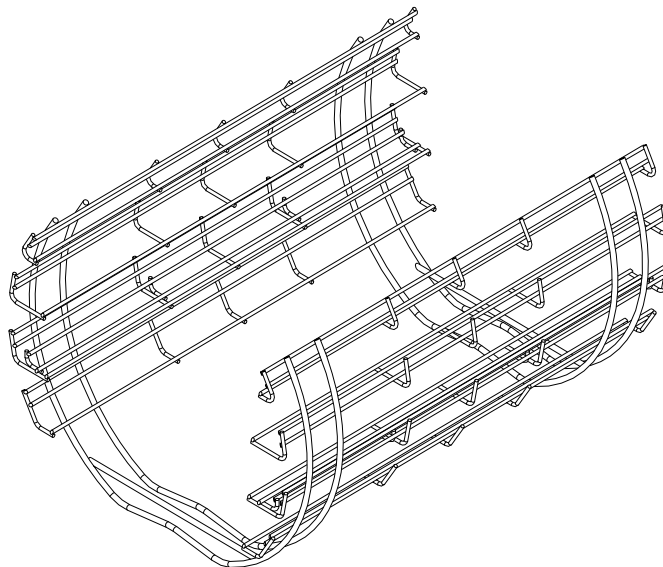

Model	Tray holder cat. No.
2340	TRH234-0008
2540	TRH254-0009

DOOR TIGHTENING BOLT – ASSEMBLY

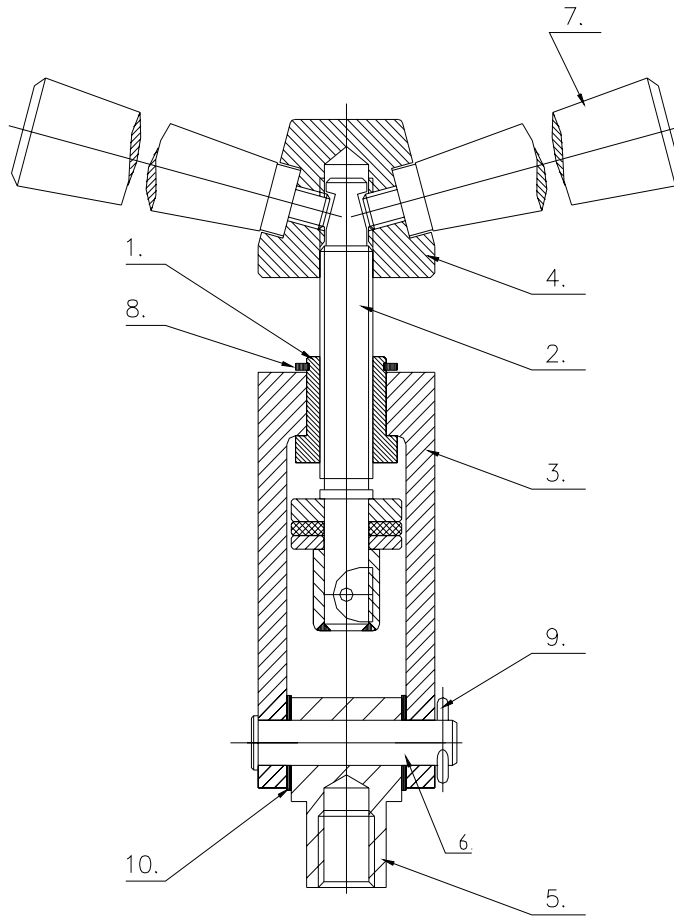

No.	Description	Cat. No.	
		1730, 2340, 2540	3545, 3850, 3870
1	Bushing	LOK240-0003	LOK387-0003
2	Door tightening bolt assembly	LOK240-0036	LOK387-0007
3	Locking screw housing	LOK240-0005	LOK387-0006
4	Locking base	LOK240-0012	LOK387-0012
5	Locking housing axis	LOK240-0014	LOK387-0014
6	Door locking device pin	LOK240-0019	LOK387-0016
7	Bakelite handle	HAN071-0003	HAN071-0006
8	Closing bridge "c" clip	NUT193-0339	NUT193-0300
9	Cotter pin	LOK692-0039	LOK692-0039
10	Okolon disc	LOK240-0017	LOK387-0017
	Bushing (1) + Locking screw housing (3) + Closing bridge "c" clip (8)	LOK240-0002	LOK387-0002
	Door tightening bolt – assembly	LOK240-0001	LOK387-0030

12. LIST OF ACCESSORIES

<i>Description</i>		<i>Cat. No.</i>					
		<i>1730</i>	<i>2340</i>	<i>2540</i>	<i>3545</i>	<i>3850</i>	<i>3870</i>
Handle, Tray, TTA 1730, 2340, 2540		CMT240-0001	CMT240-0001	CMT240-0001	—	—	—
Pouch Rack		—	ACS215-0008	ACS215-0008	—	—	ACS215-0010
Tray	Big	TRY173-0001	TRY240-0001	TRY240-0001	TRY314-0001	TRY385-0003	TRY387-0001
	Small				TRY314-0002	TRY385-0004	TRY387-0003
Holder, Tray		TRH173-0002	TRH234-0001	TRH254-0001	TRH314-0000	TRH385-0001	TRH387-0002
Holder, Tray, Wire		—	TRH234-0008	TRH254-0009	—	—	—
Silicon drain tube		GAS084-0007	GAS084-0007	GAS084-0007	GAS084-0007	GAS084-0007	GAS084-0007
Cleaning Powder, Chamber Brite, 1 Box		CLE096-0026	CLE096-0026	CLE096-0026	CLE096-0026	CLE096-0026	CLE096-0026

13. LIST OF SPARE PARTS

Description	Cat. No.					
	1730	2340	2540	3545	3850	3870
Thermostat, Cut-Off, TY95-H, Campini	THE005-0014	THE005-0014	THE005-0014	THE005-0014	THE005-0014	THE005-0014
Thermostat, Safety, 180C, TY95/AC, Campini	THE005-0003	THE005-0003	THE005-0003	THE005-0003	THE005-0003	THE005-0003
Heating Element, 120V	HEA009-0001	HEA009-0002	HEA009-0003	HEA009-0014	—	—
Heating Element, 230V	HEA009-0004	HEA009-0005	HEA009-0006	HEA009-0016	HEA009-0007	HEA009-0008
				HEA009-0015		
Circuit Breaker, 1PH, 10A, Carlingswitch	ELE035-0069	ELE035-0069	ELE035-0069	ELE035-0069	—	—
Circuit Breaker, Rail, 1PH, 15A, Carlingswitch	ELE035-0021	ELE035-0021	ELE035-0021	ELE035-0021	ELE035-0021	ELE035-0021
Timer, Mechanical, 0-60 min, Faucigny	ELE033-0001	ELE033-0001	ELE033-0001	ELE033-0001	ELE033-0001	ELE033-0001
Switch, Rocker, 16A	ELE035-0012	ELE035-0012	ELE035-0012	ELE035-0012	ELE035-0012	ELE035-0012
Microswitch, E13-00M, 15A, 125/250VAC, 3/4HP, Cheery	ELE036-0001	ELE036-0001	ELE036-0001	ELE036-0001	ELE036-0001	ELE036-0001
Microswitch, E11-00-H, Cheery	ELE036-0002	ELE036-0002	ELE036-0002	ELE036-0002	ELE036-0002	ELE036-0002
Lamp, Orange, 110V, 8mm	ELE038-0003	ELE038-0003	ELE038-0003	ELE038-0003	ELE038-0003	ELE038-0003
Lamp, Orange, 230V, 8mm	ELE038-0006	ELE038-0006	ELE038-0006	ELE038-0006	ELE038-0006	ELE038-0006
Lamp, Green, 110V, 8mm	ELE038-0002	ELE038-0002	ELE038-0002	ELE038-0002	ELE038-0002	ELE038-0002
Lamp, Green, 230V, 8mm	ELE038-0005	ELE038-0005	ELE038-0005	ELE038-0005	ELE038-0005	ELE038-0005
Gauge, Pressure, Steam, 0-60 psi, Red Pointer	—	GAU029-0005	GAU029-0005	GAU029-0005	GAU029-0005	GAU029-0005
Gauge, Pressure, Steam, 0-60 psi, 1.5"	GAU029-0008	—	—	—	—	—
Handle, Door, Bakelite for TTA (522)	HAN071-0003	HAN071-0003	HAN071-0003	HAN071-0006	HAN071-0006	HAN071-0006
Knob, Timer	HAN071-0011	HAN071-0011	HAN071-0011	HAN071-0011	HAN071-0011	HAN071-0011
Knob, Pressure switch (B10)	HAN071-0012	HAN071-0012	HAN071-0012	HAN071-0012	HAN071-0012	HAN071-0012
Cover, Door	POL065-0001	POL065-0002	POL065-0002	COV314-0001	POL065-0003	POL065-0003
Dipstick, Reservoir, Water, Superp.	POL067-0005	POL067-0005	POL067-0005	POL067-0005	POL067-0005	POL067-0005
Cover, Reservoir, Water, Superp.	POL067-0004	POL067-0004	POL067-0004	POL067-0004	POL067-0004	POL067-0004
Bellows, Door Lock	GAS080-0020	GAS080-0020	GAS080-0020	GAS080-0020	GAS080-0020	GAS080-0020
Gasket, Door	GAS080-0021	GAS080-0002	GAS080-0003	GAS080-0029	GAS080-0004	GAS080-0004

<i>Description</i>	<i>Cat. No.</i>					
	<i>1730</i>	<i>2340</i>	<i>2540</i>	<i>3545</i>	<i>3850</i>	<i>3870</i>
Disc, Silicone, Door Bellows	GAS080-0006	GAS080-0006	GAS080-0006	GAS080-0006	GAS080-0006	GAS080-0006
Gasket, Silicone, Water Reservoir	GAS080-0007	GAS080-0007	GAS080-0007	GAS080-0007	GAS080-0007	GAS080-0007
Cable, Plug+Socket 110V 15A, USA	WIR040-0004	WIR040-0004	WIR040-0004	WIR040-0004	WIR040-0004	WIR040-0004
Cable, Plug+Socket 220V 15A, USA	WIR040-0005	WIR040-0005	WIR040-0005	WIR040-0005	WIR040-0005	WIR040-0005
Multi-purpose valve assy. complete with harness	CMT173-0006	CMT240-0028	CMT240-0028	CMT314-0006	CMT385-0005	CMT387-0027
Multi-purpose valve with M.Sw.	CMT173-0026	CMT240-0046	CMT240-0046	CMT240-0046	CMT240-0046	CMT240-0046
Valve, Multipurpose, Assembly+Base	CMT173-0027	CMT240-0016	CMT240-0016	CMT240-0016	CMT240-0016	CMT240-0016
Valve, Multi-Purpose	VLV170-0067	VLV170-0065	VLV170-0065	VLV170-0065	VLV170-0065	VLV170-0065
Harness, Electrical, Valve, Multipurpose	ELC173-0002	ELE032-0001	ELE032-0001	ELC314-0005	ELC385-0006	ELC387-0015
Valve, Safety, Steam 1/4"-40 psi (ASME)	SVL029-0004	SVL029-0004	SVL029-0004	SVL029-0004	SVL029-0004	SVL029-0004
Air Jet, M/E, Black	CMT100-0006	CMT100-0006	CMT100-0006	CMT100-0006	CMT100-0006	CMT100-0006
Socket for electric cord, 15A	WIR040-0016	WIR040-0016	WIR040-0016	—	—	—
Socket for electric cord, 10A	WIR040-0003	WIR040-0003	WIR040-0003	—	—	—
Tightening bolt ½ UNC x 70	BOL194-0121	BOL194-0121	BOL194-0121	—	—	—
Tightening bolt ½ UNC x 90	BOL194-0122	BOL194-0122	BOL194-0122	—	—	—
Tightening bolt ½ UNC x 115	—	—	—	BOL194-0123	BOL194-0123	BOL194-0123
Tightening bolt ½ UNC x 155	—	—	—	BOL194-0124	BOL194-0124	BOL194-0124
Leg, Front, TTA	WHE070-0012	WHE070-0012	WHE070-0012	—	—	—
Leg, Front, Long, TTA	—	—	—	WHE070-0013	WHE070-0013	WHE070-0013
Leg, Rubber, Plug Type, 25x1/4	WHE070-0016	WHE070-0016	WHE070-0016	WHE070-0016	WHE070-0016	WHE070-0016
Reservoir, Water, Assembly	CMT173-0025	CMT240-0025	CMT240-0025	CMT240-0025	CMT387-0024	CMT387-0024
Cover, Outer	COV173-0002	COV240-0002	COV240-0002	COV314-0002	COV385-0002	COV387-0002
Rear cover	RCV173-0002	RCV240-0002	RCV240-0002	RCV314-0001	RCV387-0005	RCV387-0005
Autoclave vessel	ASM173-0001	ASM234-0001	ASM254-0001	CHM314-0000	ASM385-0001	ASM387-0001
Door Assembly	DOR173-0001	DOR234-1000	DOR254-0000	—	—	DOR387-0001
Cooling coil	SRV000-0251	SRV000-0251	SRV000-0251	SRV000-0251	SRV000-0242	SRV000-0242
Brass bolt 1/8 x 60	BOL190-0020	BOL190-0020	BOL190-0020	BOL190-0020	BOL190-0020	BOL190-0020

<i>Description</i>	<i>Cat. No.</i>					
	<i>1730</i>	<i>2340</i>	<i>2540</i>	<i>3545</i>	<i>3850</i>	<i>3870</i>
SST bolt M4 x 12	BOL191-0140	BOL191-0140	BOL191-0140	BOL191-0140	BOL191-0140	BOL191-0140
SST bolt 4M x 8	BOL191-0158	BOL191-0158	BOL191-0158	BOL191-0158	BOL191-0158	BOL191-0158
Bushing for selector valve	CMT240-0019	CMT240-0019	CMT240-0019	CMT240-0019	CMT240-0019	CMT240-0019
Microswitch D48X	ELE036-0012	ELE036-0012	ELE036-0012	ELE036-0012	ELE036-0012	ELE036-0012
Male connector 1/4 x 1/4	FIT100-0308	FIT100-0308	FIT100-0308	FIT100-0308	FIT100-0308	FIT100-0308
Male elbow 5/16 x 1/4	FIT100-0309	FIT100-0309	FIT100-0309	FIT100-0309	FIT100-0309	FIT100-0309
Brass nut 1/8	NUT192-0206	NUT192-0206	NUT192-0206	NUT192-0206	NUT192-0206	NUT192-0206
Star disk 1/8	NUT193-0290	NUT193-0290	NUT193-0290	NUT193-0290	NUT193-0290	NUT193-0290
Nut 3/8"	CMT240-0020	CMT240-0020	CMT240-0020	CMT240-0020	CMT240-0020	CMT240-0020
Screw 4M x 12	BOL191-0100	BOL191-0100	BOL191-0100	BOL191-0100	BOL191-0100	BOL191-0100
Below housing bolt	LOK240-0026	LOK240-0026	LOK240-0026	LOK240-0026	LOK240-0026	LOK240-0026
Safety membrane housing	LOK240-0025	LOK240-0025	LOK240-0025	LOK240-0025	LOK240-0025	LOK240-0025
Membrane pin	LOK240-0023	LOK240-0023	LOK240-0023	LOK240-0023	LOK240-0023	LOK240-0023
Inner bushing for bellow	CMT067-0002	CMT067-0002	CMT067-0002	CMT067-0002	CMT067-0002	CMT067-0002
Metal sheet nut 4.8 x 1.25	NUT192-0230	NUT192-0230	NUT192-0230	NUT192-0230	NUT192-0230	NUT192-0230
Metal sheet nut 4.8 x 2-5	—	NUT192-0236	NUT192-0236	NUT192-0236	NUT192-0236	NUT192-0236
Metal sheet screw 12 x 4.8	BOL194-0340	BOL194-0340	BOL194-0340	—	—	—
Metal sheet screw 10 x 3/4	—	—	—	BOL194-0341	BOL194-0341	BOL194-0341
Switch, Pressure, B10, Robert Show	THE005-0002	THE005-0002	THE005-0002	THE005-0002	THE005-0002	THE005-0002

14. CONVERSION TABLE

°F	°C	PSI	BAR
212	100	0	0
234	112	7.4	0.5
250	121	18.0	1.2
262	128	22.2	1.5
273	134	29.6	2.0
282	139	37.0	2.5
291	144	44.4	3.0

DRAWING OF ELECTRICAL SYSTEM OF TABLE AUTOCLAVE MODEL 1730M

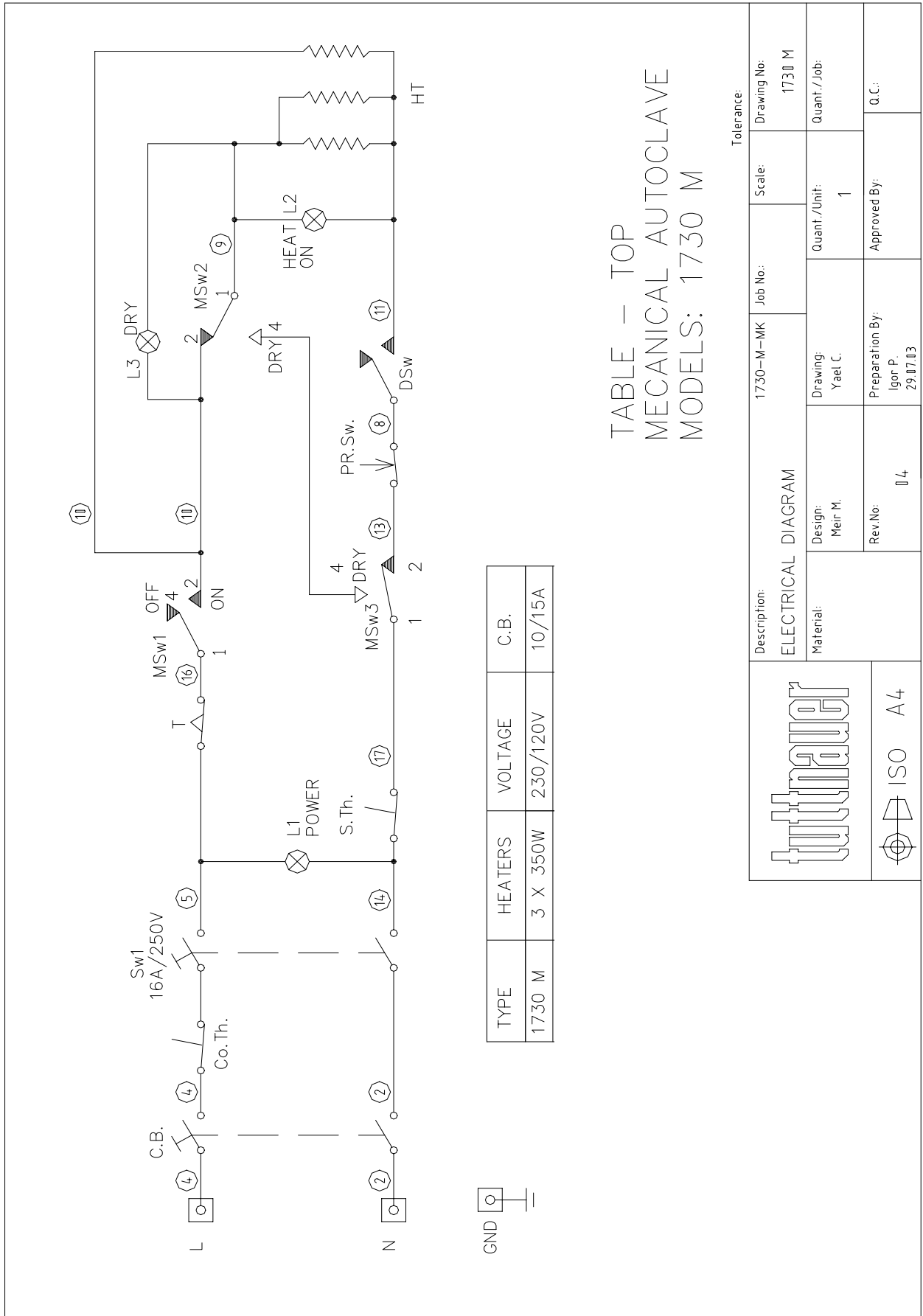

TABLE – TOP
MECHANICAL AUTOCLAVE
MODELS: 1730 M

Description:		1730-M-MK		Job No.:		Drawing No:	
ELECTRICAL DIAGRAM		1730 M		Scale:		1730 M	
Material:		Design: Meir M.		Drawing: Yaet C.		Quant./Unit: 1	
Rev.No.:		14		Preparation By: Igor P.		Approved By:	
ISO A4				29.07.03		Q.C.:	

DRAWING OF ELECTRICAL SYSTEM OF TABLE AUTOCLAVE MODELS 2340/2540 M

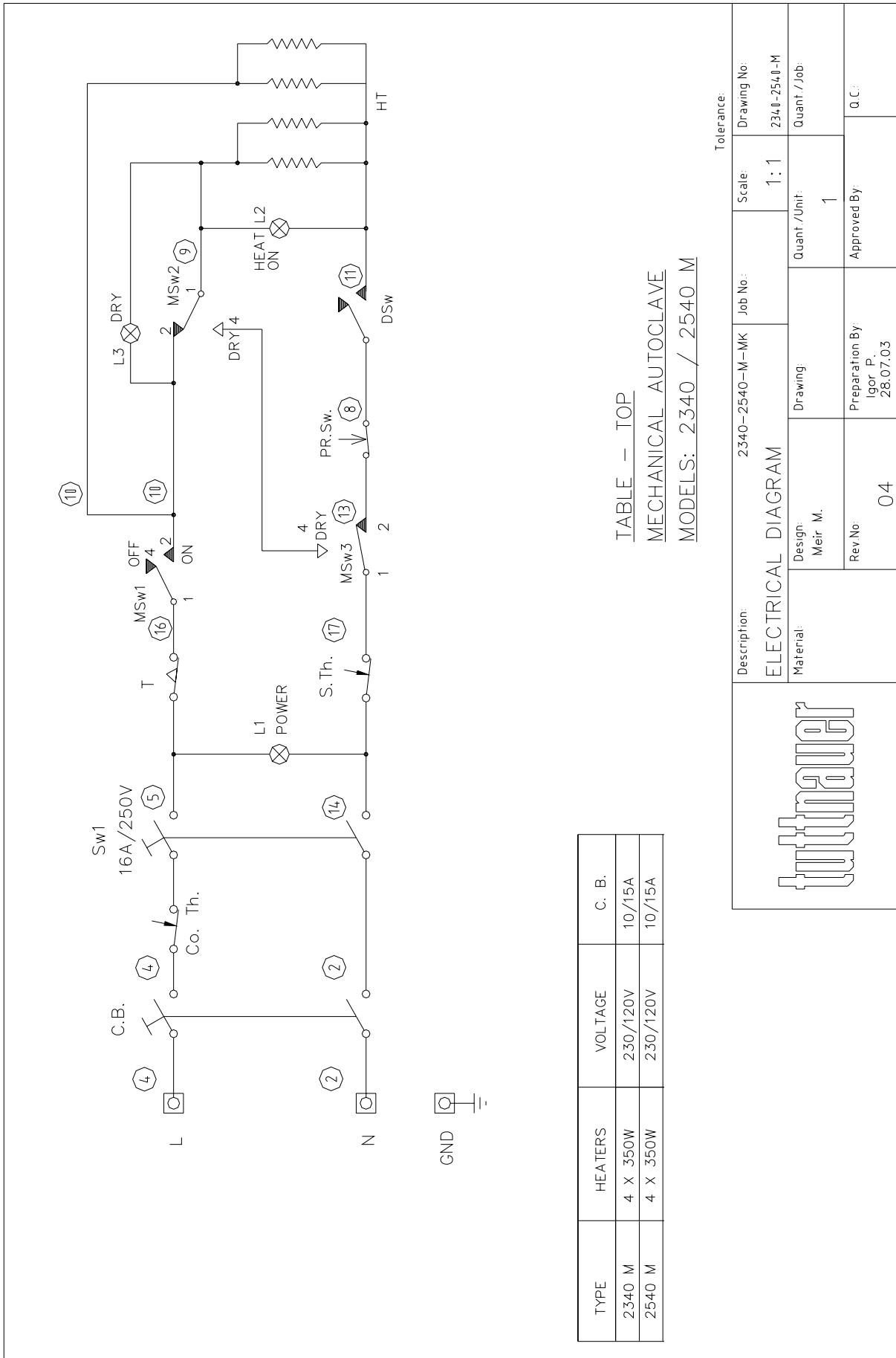

TABLE – TOP
MECHANICAL AUTOCLAVE
MODELS: 2340 / 2540 M

TYPE	HEATERS	VOLTAGE	C. B.
2340 M	4 X 350W	230/120V	10/15A
2540 M	4 X 350W	230/120V	10/15A

Wittman	Description: 2340-2540-M-MK		Job No.:	Scale:	Drawing No:
	ELECTRICAL DIAGRAM			1:1	2340-2540-M
	Material:	Design: Meir M.	Drawing:	Quant / Unit:	Quant / Job:
	Rev.No 04	Preparation By: Igor P. 28.07.03		1	
		Approved By:			Q.C.:

Tolerance:

DRAWING OF ELECTRIC SYSTEM OF TABLE AUTOCLAVE MODEL 3545 M

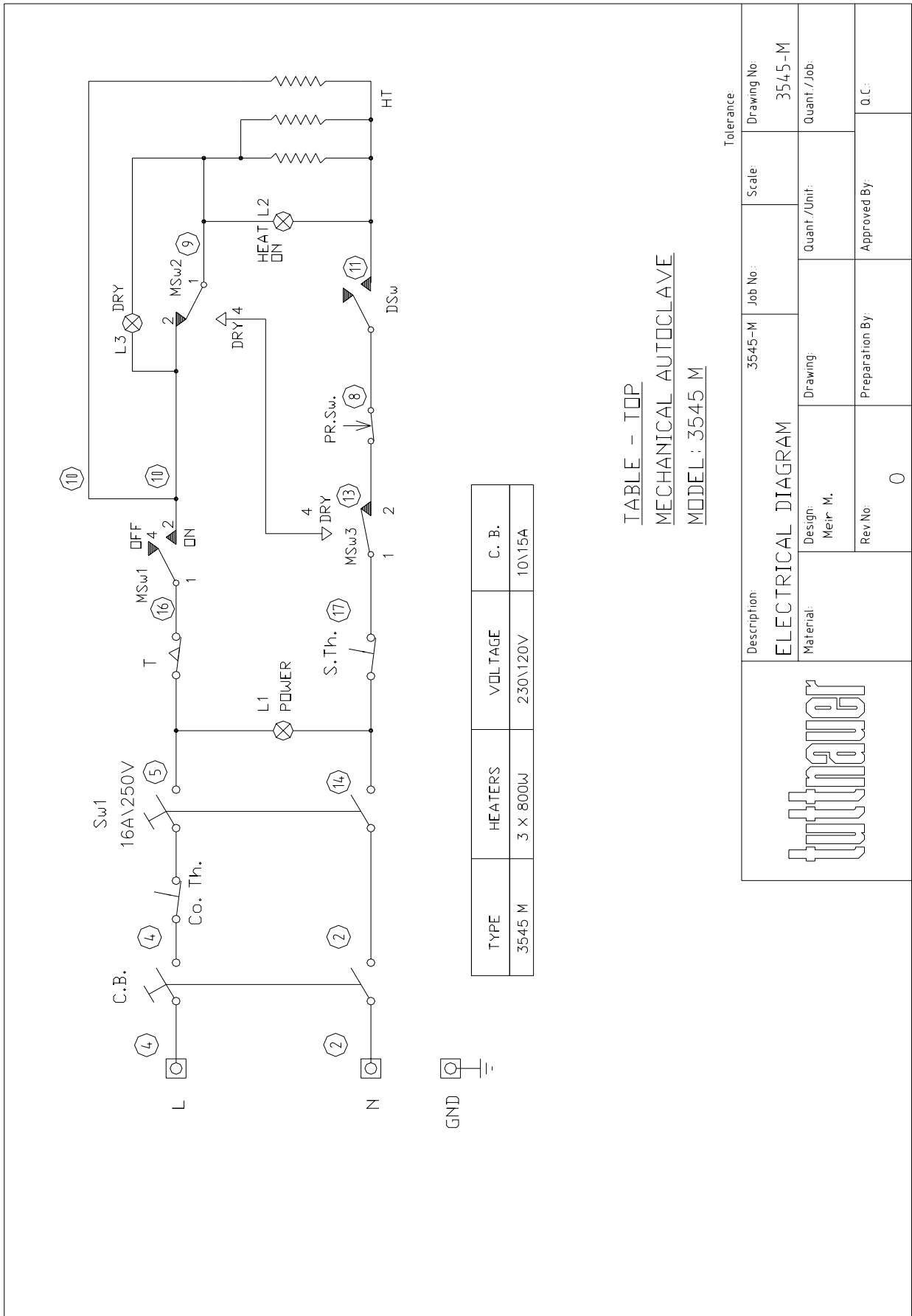

DRAWING OF ELECTRIC SYSTEM OF TABLE AUTOCLAVE MODEL 3850 M

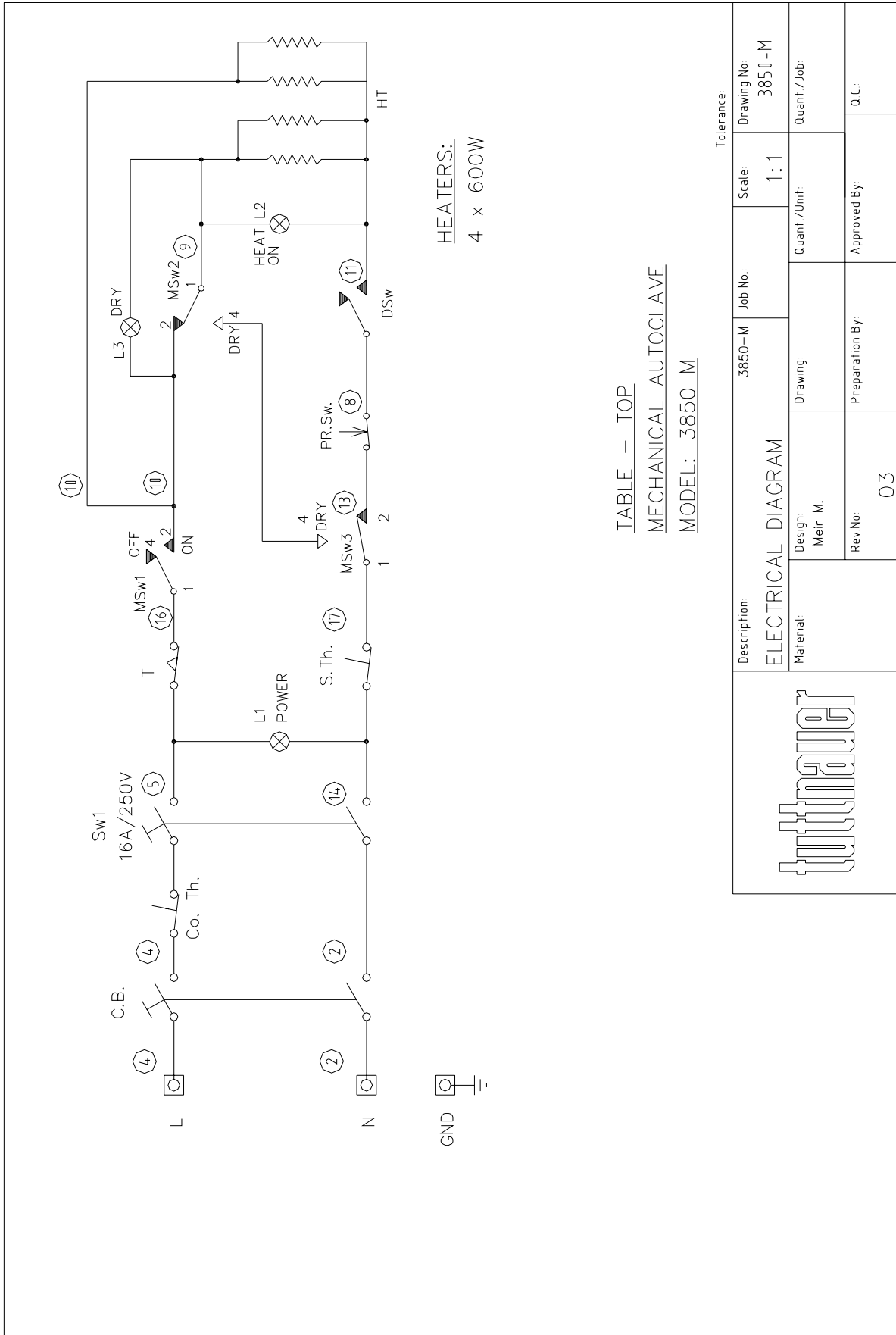

TABLE -- TOP
MECHANICAL AUTOCLAVE
MODEL: 3850 M

Description:		3850-M	Job No.:	3850-M	Scale:	1:1	Drawing No:	3850-M
ELECTRICAL DIAGRAM		Material:	Design:	Meir. M.	Drawing:	Quant./Unit:	Quant./Job:	
		RevNo:	03	Preparation By:	Approved By:	Q.C.:		

DRAWING OF ELECTRICAL SYSTEM OF TABLE AUTOCLAVE MODEL 3870 M

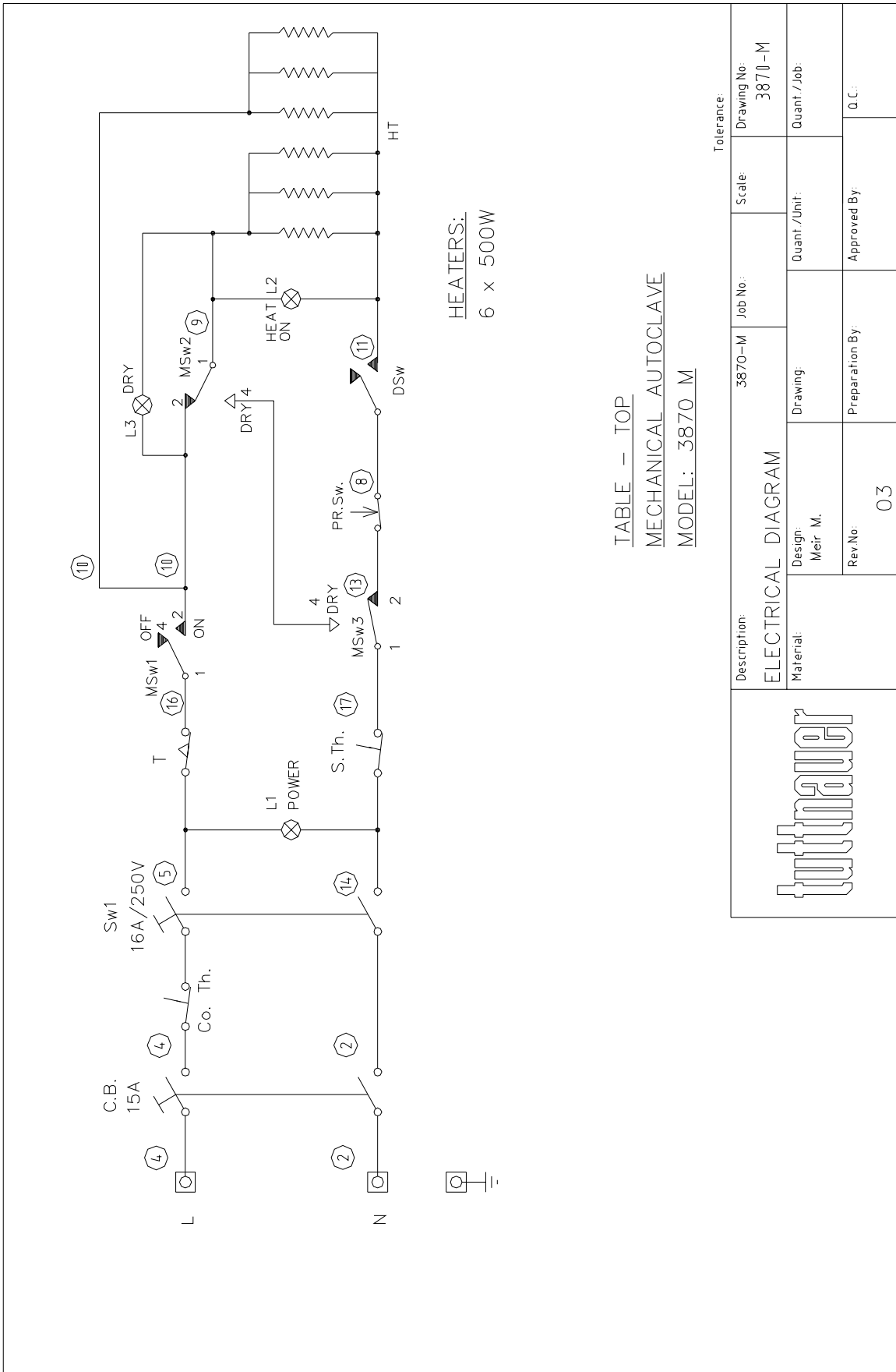
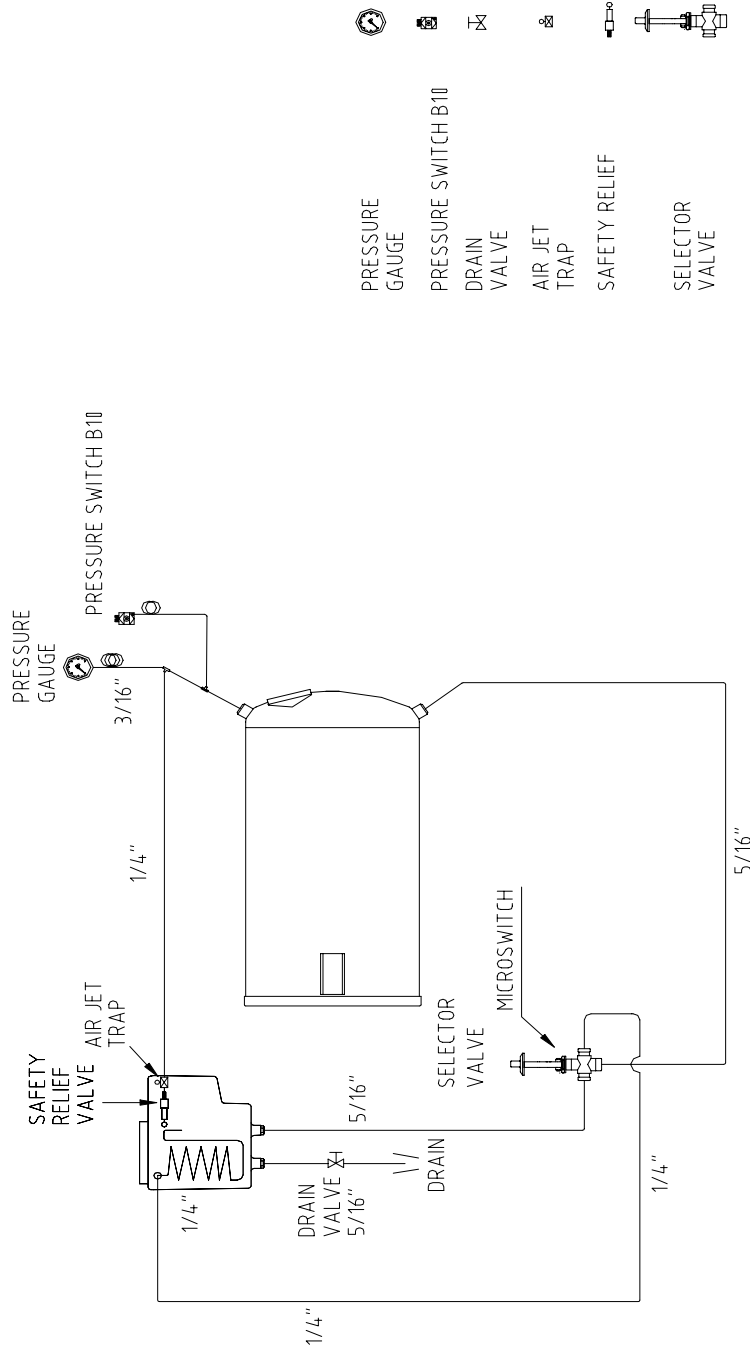

TABLE - TOP
MECHANICAL AUTOCLAVE
MODEL: 3870 M

tuttnauer	Description: 3870-M Job No:		Scale:		Drawing No: 3870-M		
	ELECTRICAL DIAGRAM		Drawing:		Quant./Job:		
Material: Meir M.		Drawing:		Quant./Unit:		Approved By:	
Rev No: 03		Preparation By:		Approved By:		Q.C.:	

PIPING DIAGRAM TABLE TOP AUTOCLAVE



Tolerance: ±0.3

TABLE-TOP MECHANICAL AUTOCLAVE

MODELS: M

Drawing No. 1203

Description:		M	Job No.:	Scale:	Drawing No:
PIPING DIAGRAM				1:1	PD12030
Material:	Design:	Drawing:	Quant./Unit:	Quant./Job:	
	Meir M. 16.04.2000	Dmitry Z. 16.04.2000	1		
	Rev.No:	Preparation By:	Approved By:	Q.C.:	