

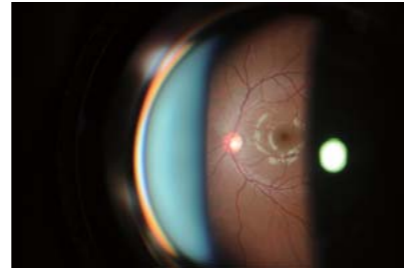

Righton 78D and 90D lens holders are attachable for Righton slit lamps, making possible hassle-free fundus and vitreous imaging.

For observation, simply adjust the slit lamp position and set the lens to infinity. Available with Righton slit lamps.



78D and 90D lenses for use with slit lamps

Guide

The height of the slit beam should not exceed the patient's pupillary dilation.

	Distance to	Lens edge	Corneal apex
Slit lamp tower	78D	110 mm	128 mm
Move tower 10 to 12 degrees away from center	90D	109 mm	124 mm

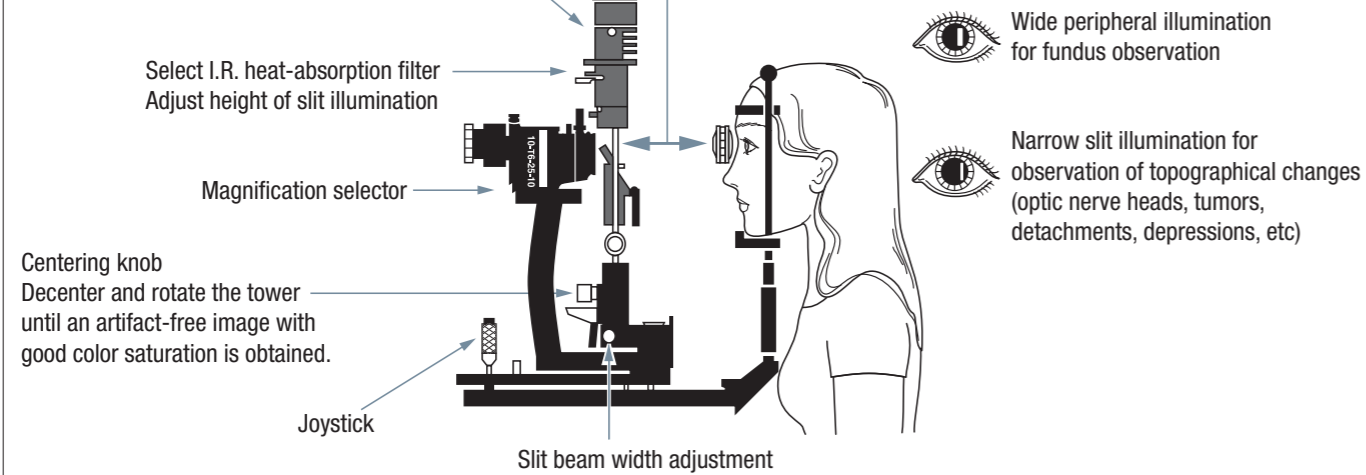

Caution!

How to sterilize lenses

Cleaning: Clean the lens with alcohol.

Disinfecting: Place the lens in 2% glutaraldehyde for 25 minutes. Alternatively, dilute sodium hypochlorite (household bleach) in water at a ratio of 10:1 and place the lens in the bleach solution for 25 minutes.

Sterilizing: Sterilize the lens with ethylene oxide gas and allow it to aerate at a temperature of 50°C to 60°C.

Warning: Do not use autoclave sterilization, boiling sterilization or plasma sterilization.



WARNING:

To ensure correct usage, read all manuals carefully before using equipment

Specifications and equipment are subject to change without any notice or obligation on the part of the manufacturer. The information in this brochure is correct as of August 2013.

© 2013 RIGHT MFG. CO., LTD.



MERCOFRAMES OPTICAL CORP.

© 5555 NW 74 AVE. Miami, FL 33166 [/mercoframes](https://www.mercoframes.com)
 ✉ sales@mercoframes.net www.mercoframes.com
 ☎ 305-882-0120 www.mercoframesusa.com



Aspherical Lens

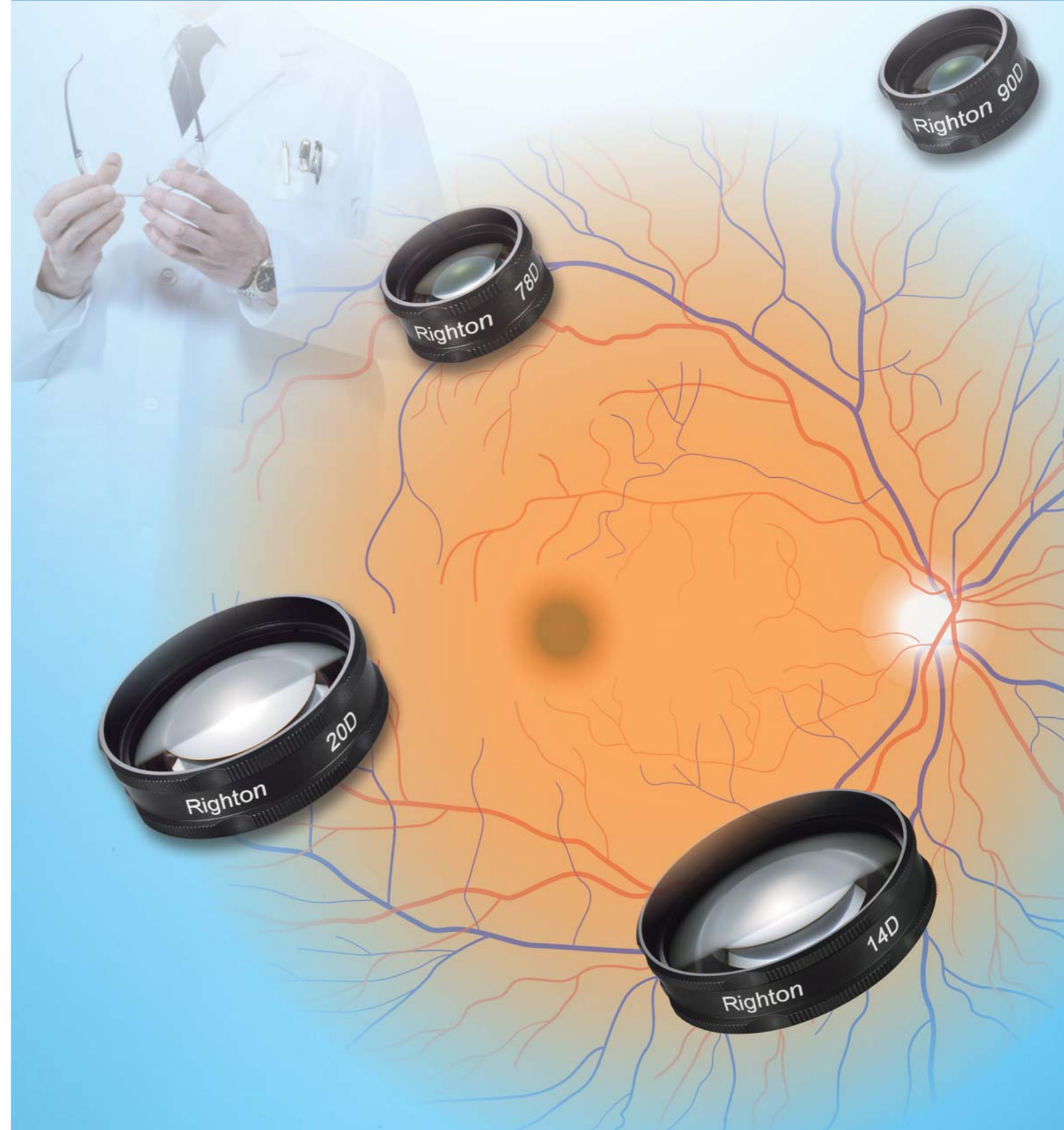

The Legend Revived!

Extremely comfortable to use

Fit snugly into the hand

Following a tradition of Japanese-made premium lenses

- The aplanat design ensures images with even illumination and low aberration.

14D 20D

- Clear and bright images
- Wider effective diameters
- Multilayer coating on lenses greatly reduces reflections
- Undistorted peripheral visual field
- Easy-to-hold high-quality lens frames

78D 90D

- Excellent working distance
- Wider field of view
- Sharp images that work best with slit lamps
- Comfort ensured during lengthy use
- Reflections eliminated by multilayer coating

High-quality manufacture using eco-friendly materials and processes



14D For larger image observation

Effective diameter	Focal length	Center thickness	Field of view	Working distance	Weight
52 mm	71.4 mm	12 mm	35°	77 mm	60 g

- Aspherical



20D Best standard for indirect ophthalmoscopy

Effective diameter	Focal length	Center thickness	Field of view	Working distance	Weight
49 mm	50 mm	14.5 mm	45°	50 mm	59 g

- Aspherical



78D Best use for slit lamp

Effective diameter	Focal length	Center thickness	Field of view	Working distance	Weight
24 mm	12.8 mm	10.5 mm	60°	8.0 mm	23 g

- Dual aspherical



90D Best use for slit lamp

Effective diameter	Focal length	Center thickness	Field of view	Working distance	Weight
21 mm	11.1 mm	10 mm	60°	6.0 mm	19 g

- Dual aspherical

Easy-to-grip lens frames

Introducing the dimple and knurled lens frame design
Comfortable and easy to hold



Lens cases (included)

