

---

# HYDRIM C61w G4

INSTRUMENT WASHER

---

- Operator's Manual



HYDRIM C61w G4 Operator's Manual 95-113022 Rev. 2.0 Copyright 2013 SciCan Ltd . All rights reserved.

**SciCan** |

Your Infection Control Specialist™

# Contents

<b>1. Introduction .....</b>	<b>3</b>	<b>4. Using your HYDR/M .....</b>	<b>19</b>
<b>2. Important Information .....</b>	<b>4</b>	Instrument reprocessing recommendations	
Disclaimer		Cycle description charts	
Unit overview		Baskets and accessories	
Touchscreen overview		Hints and tips for best cleaning results	
Set-up menu overview		Recommended load configurations	
<b>3. Setting up your HYDR/M .....</b>	<b>8</b>	Running a cycle	
Installation		Interrupting / aborting a cycle	
Handling and installing HIP™ Ultra		Additional user and setup menu functions	
cleaning solution		Opening the door in case of power failure	
Water quality		<b>5. Storing and Retrieving</b>	
Testing water quality		<b>Cycle Information .....</b>	<b>28</b>
Disposing of packaging and		Retrieving cycle information using	
decommissioned units		the touchscreen	
Setting language		Retrieving cycle information using	
Setting country		the USB data back up	
Setting time		<b>6. Care and Maintenance.....</b>	<b>30</b>
Setting date		Replacing the HIP™ Ultra cleaning solution	
Assigning unit identifier number		Refilling the water softening salt reservoir	
Resetting drying counter		Changing the air filter	
Adjusting screensaver delay		Filter and wash arm maintenance	
Adjusting temperature delay		Cleaning the unit	
Turning the button sound ON or OFF		Preparing the unit for shipping	
Adjusting button beep volume		Annual maintenance	
Adjusting salt regeneration		Unit testing and validation	
Adjusting screen contrast		<b>7. Troubleshooting .....</b>	<b>36</b>
Changing touchscreen display themes		Troubleshooting general problems	
Creating a user name		Troubleshooting error messages	
Creating a user PIN		<b>8. Warranty .....</b>	<b>40</b>
Setting up process enforced usage		<b>9. Specifications .....</b>	<b>41</b>
Connecting to a network			
Connecting to a wireless network			

# 1 Introduction

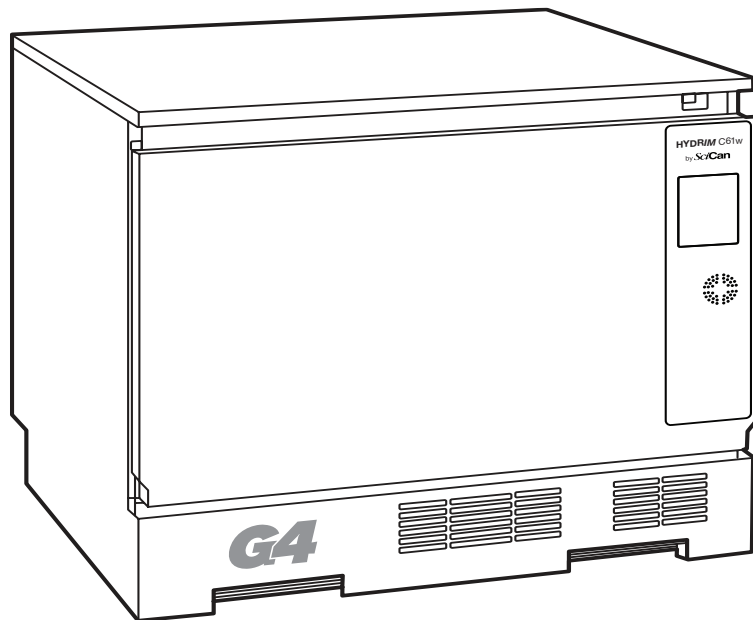

! Thank you for selecting the HYDRIM C61w G4 instrument washer. The HYDRIM complements the STATIM® and BRAVO™ autoclaves by quickly and hygienically preparing soiled instruments for sterilization. To ensure years of safe, trouble-free service, carefully review this Operator's Manual before operating the unit. The HYDRIM C61w G4 is suitable only for the applications listed in this manual. Using the HYDRIM for other purposes may be dangerous. The manufacturer cannot be held responsible for damage caused by improper use.

! Operational, maintenance and replacement instructions must be followed for the product to perform as designed. All trademarks referred to in this manual are the property of their respective owners. Contents of this manual are subject to change without notice to reflect changes and improvements to the HYDRIM product.

! The HYDRIM should only be installed and serviced by a qualified contractor as the HYDRIM C61w G4 is an Installation Category II device. Before connecting the unit, the installer should check that the voltage and frequency of the electrical supply correspond with the details in the installation instructions. The unit must only be plugged into a grounded outlet. Please note that this unit is completely isolated from the electrical supply only when it is unplugged or the circuit breaker is turned OFF. This must be done before any repair work is carried out.

! The HYDRIM C61w G4 uses HIP™ Ultra cleaning solution exclusively. The unit will not perform as described if detergents or cleaning products not approved by SciCan are used. Other detergents or cleaning products may damage the unit, the instruments, cause excessive foaming, and void the warranty. Do not use solvents in this unit. Do not allow unauthorized personnel access to this unit or its controls.

## 2 Important Information

### 2.1 Disclaimer

Do not permit any person other than authorized personnel to supply parts for service or maintenance for your HYDR/M. SciCan is not liable for incidental, special or consequential damages caused by any maintenance or services performed on the HYDR/M by unauthorized personnel, or for the use of equipment or parts manufactured by a third party, including lost profits, any commercial loss, economic loss, or loss arising from personal injury.



Never remove any unit panels and never insert objects through holes or openings in the cabinetry. Doing so may damage the unit and/or pose a hazard to the operator.



If the unit is used in a manner other than that specified, the protection provided by the equipment may be impaired.



Cleaning solutions may irritate. Avoid contact with eyes and mouth.



Never sit, stand or lean on the open door. The unit may tip forward causing injury.



Always turn the unit OFF before adding softener salt, adding solutions or performing routine maintenance to the unit.



The owner shall not allow any personnel other than the trained and authorized personnel to operate the unit.



SciCan recommends leaving the unit turned ON at all times, in particular over times when no staff is in the office when no water shut-off mechanism is installed. Leaving the unit turned ON will activate the drain pump if water is leaking into the chamber as a result of any faulty circumstance.

# 2 Important Information

## 2.2 HYDRIM Unit overview

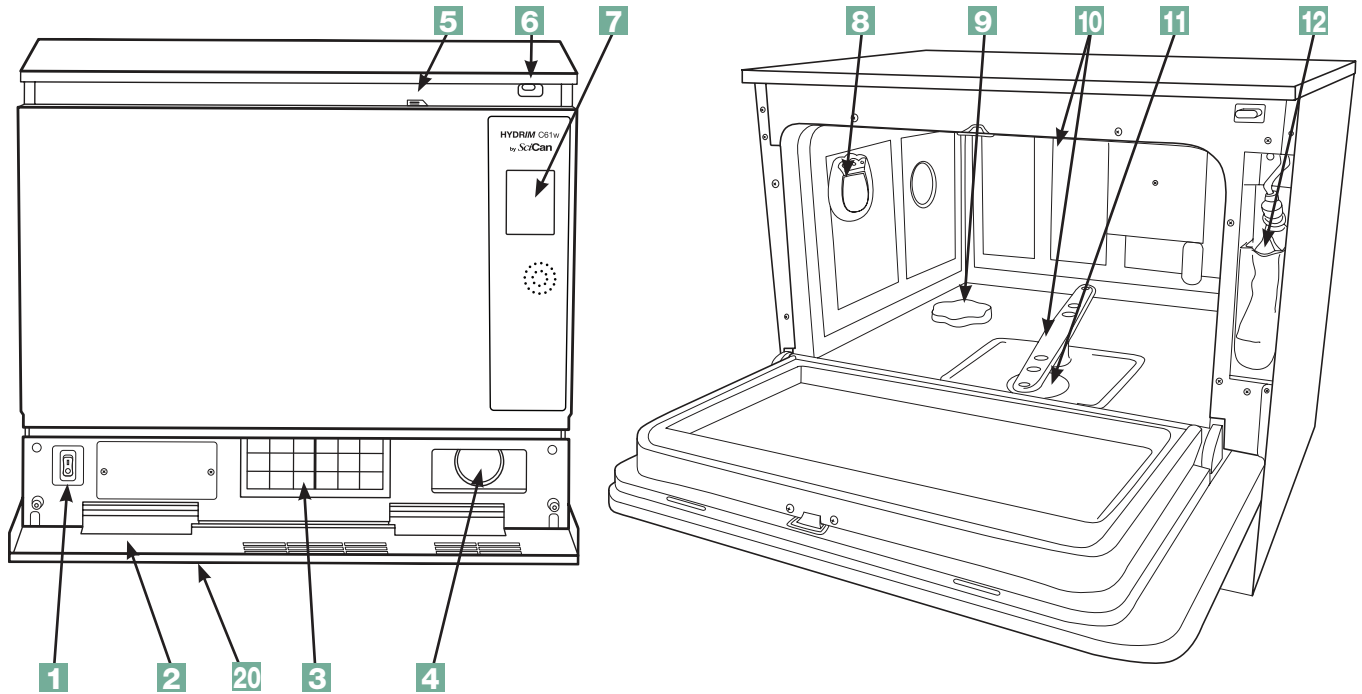

- |                          |  |  |
|--------------------------|--|--|
| <b>1</b> Power switch    | <b>8</b> Dryer outlet                  | <b>14</b> Ethernet port                |
| <b>2</b> Kickplate       | <b>9</b> Water softener                | <b>15</b> RS232 port                   |
| <b>3</b> HEPA filter     | <b>10</b> Wash arms (top not shown)    | <b>16</b> Cold water inlet             |
| <b>4</b> Dryer exhaust   | <b>11</b> Coarse filter                | <b>17</b> Hot water inlet              |
| <b>5</b> Door latch      | <b>12</b> Cleaning solution and drawer | <b>18</b> Fuses                        |
| <b>6</b> USB port        | <b>13</b> Drain outlet                 | <b>19</b> Power cable port             |
| <b>7</b> LCD touchscreen |  | <b>20</b> Drain tube (underneath unit) |

### Rear Connections

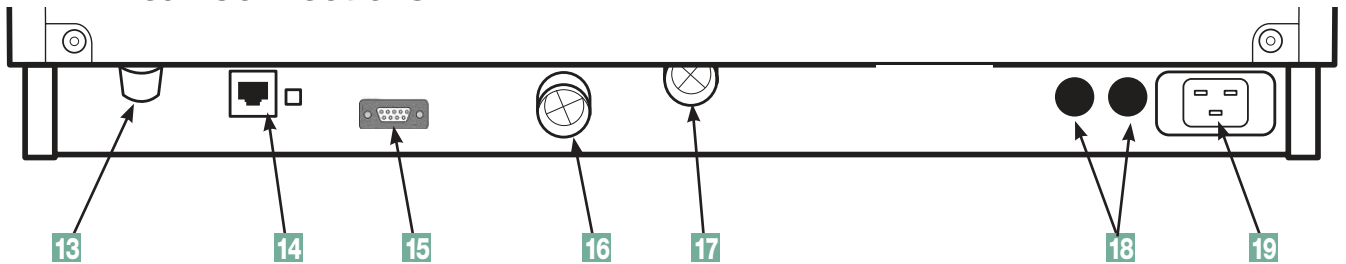

The following symbols appear in the margins of this book.



A potential hazard to the operator.



A situation that may lead to a mechanical failure.



Important information

The following symbols appear on the unit:



Caution: Hot Surface and/or Hot Steam



Caution: Risk of electrical shock. Disconnect supply before servicing.



Caution: Refer to manual for details.

## 2 Important Information

### 2.3 Touchscreen overview

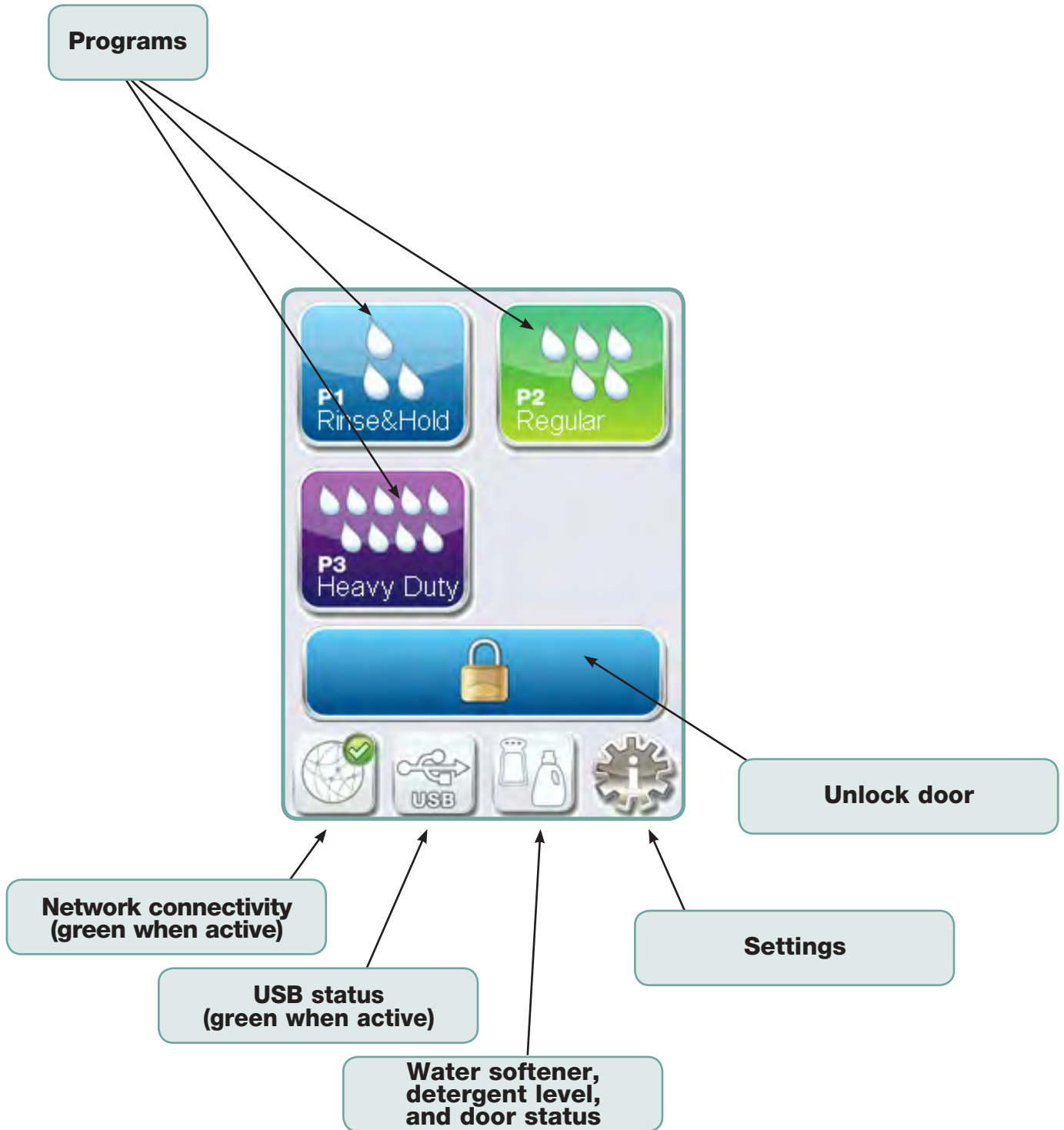

# 2 Important Information

## 2.4 Set up menu overview

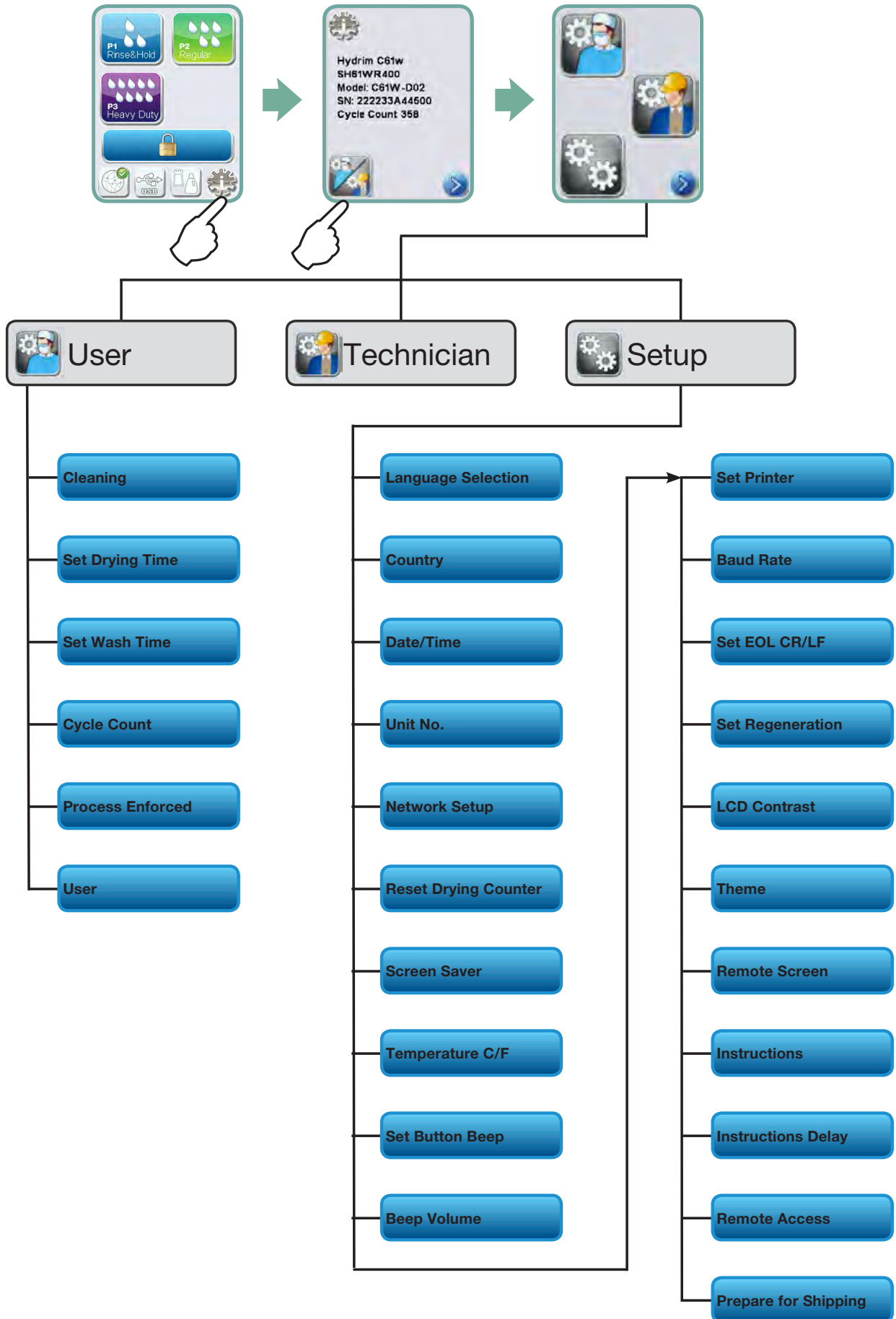

## 3. Setting up your HYDRIM

### IMPORTANT INFORMATION

- To open the wash chamber door if the door is locked and the unit is not functional, release the lever located on the top edge of the door and pull the door open. (For more detail, see section 4.9 Opening the door in case of a power failure.)
- Ensure that HIP™ Ultra cleaning solution (instrument wash chemical) is available. All other supplies are included with your unit.
- The HYDRIM C61w G4 is heavy (44 kg). Exercise caution when moving it.
- The HYDRIM C61w G4 must be properly grounded.
- The HYDRIM C61w G4 is equipped with an air gap / anti-suction device to prevent backflow of dirty water into the water supply. No other air gap device is necessary.

### 3.1 Installation

Installation should only be undertaken by a SciCan approved technician. The use of an unapproved installer may invalidate the warranty. A separate pre-installation checklist should have been supplied by your dealer. Please review this prior to approving installation.

If the HYDRIM C61w G4 is installed in a sterilization center, the manufacturer of the sterilization center should allow enough space at the top, back and both sides of the unit to facilitate installation, leveling, and service access to the unit.



Do not move the HYDRIM C61w G4 into place by maneuvering the open wash chamber door. This may cause the door to become misaligned and can cause leakage.

During installation, all consumables should have been added to the machine as appropriate. It is important to check that this has been undertaken before starting the machine.

### 3.2 Handling and installing the HIP™ Ultra cleaning solution

The HIP™ Ultra cleaning solution is used in dilute form as a detergent for the cleaning of surgical instruments in the HYDRIM range of washers and washer disinfectors. It is a colourless and almost odourless liquid which is completely soluble in water.

The pH range is between 9.3 – 9.8 and the solution is therefore mildly alkaline. It is therefore advised that certain precautionary measures are observed when handling during the loading of the solution into the machine, and when removing and disposing of the empty bag.



### 3. Setting up your HYDRIM



Recommended precautionary measures with regard to safe handling of HIP™ Ultra cleaning solution.

- Always wear undamaged gloves made of natural or butyl rubber, nitrile, or neoprene (Surgical gloves are ideal).
- Always wear eye protection.
- Protect exposed skin on arms.
- If solution is spilled on clothing, remove the item of clothing and wash affected skin with plenty of water, in accordance with the Material Safety Data Sheet requirements.
- Use good industrial hygiene practices in handling this material. When handling, do not eat or drink.
- After handling the product, remove and dispose of gloves and wash hands prior to removing eye protection.
- Do not use the personal protective equipment you use for clinical activities to handle HIP™ products.
- Always ensure that personal protective equipment, if contaminated with HIP™ Ultra cleaning solution, is cleaned, or disposed of as appropriate.

For comprehensive data on HIP™ Ultra cleaning solution, please visit [SciCan.com](http://SciCan.com) to view or download a PDF of the Material Safety Data Sheet.

To install the HIP™ Ultra cleaning solution bag, follow these steps:

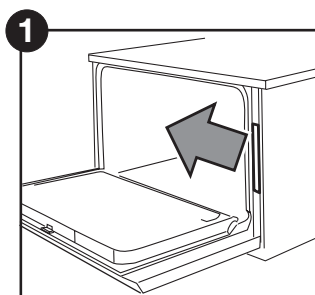

1

Turn the power OFF, open the door and pull out the chemical drawer.

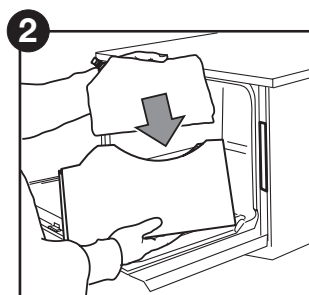

2

Place a new bag in the chemical drawer.

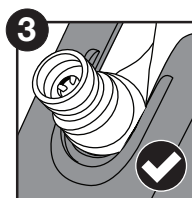

3

Ensure the nozzle is in the correct position.

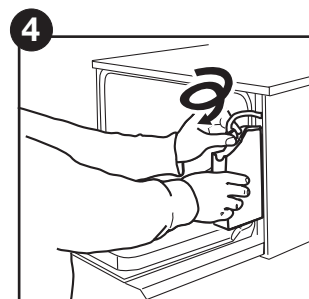
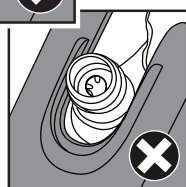

4

Connect the new bag, close the door and power the unit ON.

## 3. Setting up your HYDRIM

### 3.3 Water quality

The quality of the water being used in the HYDRIM to clean the instruments is very critical to achieving satisfactory cleaning results and to protecting the instruments and the internal parts of the unit from deterioration.

Drinking water typically contains many dissolved solids. The amount of dissolved solids greatly depends on the local natural geological conditions and they can cause stains, spots and corrosion on instruments and on the internal parts of the HYDRIM. Among others, Iron, Manganese, Chloride, and Calcium Carbonate ( $\text{CaCO}_3$ ) are the dominant dissolved solids that affect the cleaning results when using a washer.

Iron and Manganese can cause orange and brown or black stains on the instruments and on the internal parts of the HYDRIM. Chloride is usually responsible for causing stains, spotting, pitting and scaling. If the instruments or the inner parts of the HYDRIM C61w, such as the chamber, show any of these spots or stains, a water test may be required to determine the cause. The installation of a water treatment system may be required to reduce the amount of dissolved solids in the water and to improve the cleaning performance of the HYDRIM.

Calcium Carbonate is the principle cause of water hardness and leaves white spots or scales. The HYDRIM is equipped with a built-in water softening system that must be adjusted according to the local water hardness. Please see section 3.4 of this manual for recommended regeneration settings.

Before using the HYDRIM, SciCan recommends testing the water and recording the results for water hardness, pH value, and water conductivity for future references in the pre-installation and installation documents.

**IMPORTANT:** The HYDRIM's water softening system reduces the water hardness by taking out Calcium Carbonate. If your water testing results show that your water hardness is outside the unit's range of adjustment, or if other dissolved solids in the water cause stains or deposits on the instruments or chamber, an external water treatment system may be required.

### 3. Setting up your HYDR/IM

#### 3.4 Testing water quality

The HYDR/IM C61w G4 is equipped with a built-in water softening system that must be adjusted according to the local water hardness. To read local water hardness, proceed as follows:

1. The water test kit included with your HYDR/IM contains three water hardness test strips in bags. Take a water sample from the location where the machine will be installed.
2. Open one of the bags, remove the test strip and dip it into the water.
3. Compare the color of the strip with the chart on the back of the bag. Determine the water hardness according to the chart on the water test kit envelope.
4. Power the unit on and select the Settings key from the main menu.
5. Go to the Setup Menu and select "Set Regeneration".
7. Using the up and down arrows, set the water softener regeneration level according to the water hardness table in this section. If your water hardness falls between two settings, select the higher setting.
8. Unscrew the water softener container lid from the bottom left of the chamber and pour 0.5 litres of water into the water softener container.
9. Add 0.5 kg of water softening salt to the water softener container, using the supplied funnel to prevent any salt from spilling into the chamber, and close by screwing the lid **tightly** back into place. An improper seal can lead to corrosion.

Water Hardness Conversion and salt regeneration levels

	°dH	US GPG	PPM (mg CaCO <sub>3</sub> / Litre)	Regen.
Typically No Treatment Necessary (values from 18-143)	1	1.0	18	1
	2	2.1	36	
	3	3.1	54	
	4	4.2	71	
	5	5.2	89	
	5.6	5.8	100	
	6	6.3	107	2
	6.2	6.4	110	
May Require External Treatment (values from 150-535)	7	7.3	125	3
	8	8.3	143	
	8.4	8.8	150	
	9	9.4	161	
	10	10.4	178	
	10.1	10.5	180	
	11	11.5	196	
	11.2	11.7	200	
	11.8	12.3	210	4
	12	12.5	214	
	13	13.6	232	5
	14	14.6	250*	
	15	15.6	268	
	16	16.7	286	
	16.8	17.5	300	
	17	17.7	303	
	18	18.8	321	6
	19	19.8	339	
	19.6	20.5	350	
	20	20.9	357	
	20.2	21.0	360	
	21	21.9	375	
22	22.9	393	7	
22.4	23.4	400		
23	24.0	411		
24	25.0	428		
25	26.1	446		
25.2	26.3	450		
26	27.1	464		
27	28.2	482		
28	29.2	500		
28.6	29.8	510	8	
29	30.2	518		
30	31.3	535		
30.3	31.6	540		
External Treatment Required (values >535)	>30.3	>31.6	>540	

\*Please note: The water test strip is only accurate up to 250 ppm. If the reading on the test strip exceeds 250 ppm and/or if the location in which the HYDR/IM is installed has known water quality problems, having a more detailed and accurate water test done by a test lab is strongly recommended.

## 3. Setting up your HYDR/M







### 3.5 Disposing of packaging and decommissioned units

Your unit is shipped in a corrugated cardboard box and packed with protective material. Please do not add these materials to your regular domestic waste. Instead, look to reduce the amount of waste diverted to landfill by recycling these materials. Break down the cardboard box so that it can be easily handled, and contact your municipality to learn about its policy regarding the recycling of soft polyethylene engineered foam. Some municipalities operate packaging collection points with dedicated disposal bins to accommodate various materials.





A decommissioned washer should not be disposed of in the regular domestic waste. Doing so is potentially harmful to people and the environment. It has been used in a healthcare setting and represents a minor infection control risk. It also contains several recyclable materials that can be extracted and reused in the manufacture of other products. Contact your municipality to learn about its policies and programs governing the disposal of electronic devices.

### 3.6 Setting the language





The messages displayed by your HYDR/M can be presented in a number of different languages. To change the current language, follow these steps:

1.  →  → 
2. Scroll to  and select.
3. From the LANGUAGE screen, press   to scroll through the list of languages. When you have found the desired language, press  to save your selection and return to the Setup menu.

### 3.7 Setting the country









1.  →  → 
2. Scroll to  and select.
3. Using the keypad, type the name of the country and press  to select. Press  to save and return to the Setup menu.

### 3.8 Setting the time









1.  →  → 
2. Scroll to  and select.
3. From the TIME screen, use the keypad to set the time. Press  to save and  to return to the Setup menu.

## 3. Setting up your HYDR/M







**NOTE:** If the HYDR/M is connected to a network, it is important to also enter the correct Time Zone. Enter the Time submenu, select Time Zone and scroll and select your local time zone.

4. To change your unit to display 12-hour time format (24-hour time format is the default setting), go to the Setup menu and use   to scroll to TIME 12/24, select it and toggle to 12. Press  to save and return to the Setup menu.
5. To activate daylight savings time (DST), go to the Setup menu and use   to scroll to DST ON/OFF and select. Use   to toggle DST ON or OFF and press the  to save and return to the Setup menu.

### 3.9 Setting the date





1.     
2. Scroll to  and select.
3. From the DATE screen, use the keypad to set the date. Press  to save and  to return to the Setup menu.
4. To change the format in which the date appears, return to the Setup menu and use   to scroll to DATE FORMAT. Select it, and follow the prompts to have the date displayed in the desired format. Press  to save and return to the Setup menu.

### 3.10 Assigning unit identifier number

1.     
2. Scroll to  and select.
3. Using the keypad, select a maximum of 3 digits to be used as the unit's identifier number. Press  to save and  to return to the Setup menu.

### 3.11 Resetting the drying counter







The drying counter must be reset when the HEPA filter is changed. To reset the drying counter, follow these steps:

1.     
2. Scroll to  and select.
3. Select Default 0 to reset.







## 3. Setting up your HYDRIM

### 3.12 Adjusting the screensaver delay

To change the length of time before the screensaver is activated, follow these steps:

1.  →  → 
2. Scroll to **Screensaver** and select.
3. Use   to scroll through your time options. When you have found the amount of time you require, press it. Press  to save and return to the Setup menu.

### 3.13 Adjusting the temperature display







1.  →  → 
2. Scroll to **Temperature C/F** and select.
3. Use   to choose between having information displayed in degrees Celsius or Fahrenheit. Press  to save and return to the Setup menu.

### 3.14 Turning the button sound ON or OFF

The HYDRIM is preset to beep when a button is pressed. If you would like to turn the button sound off, follow these steps:









**NOTE:** Turning OFF the button sound does NOT turn off other alarms and cycle notification beeps.

1.  →  → 
2. Scroll to **Beep ON/OFF** and select.
3. Use   to scroll through your ON or OFF options and select it by pressing it. Press  to save and move back to the Setup menu.

### 3.15 Adjusting the button beep volume





If you would like to adjust the beep volume, follow these steps:

1.  →  → 
2. Scroll to **Beep Volume** and select.
3. Use   to scroll through the volume settings. Select the one you want by pressing it. Press  to save and move back to the Setup menu.

## 3. Setting up your HYDRIM





### 3.16 Adjusting the salt regeneration

Salt regeneration should be set according to the local water hardness. See section 3.4 Testing Water Quality for instructions on determining correct settings. To set salt regeneration, follow these steps:

1. 
2. Scroll to **Set Regeneration** and select.
3. Use   to change the value. The default setting is 1. Press  to save and return to the Setup menu.





### 3.17 Adjusting the screen contrast

The touchscreen is calibrated for the lighting condition of most sterilization centers. Should you need to adjust the contrast for your office, follow these steps:

1. 
2. Scroll to **LCD Contrast** and select.
3. Use   to scroll through your contrast options. When you have found the contrast you require, press it. Press  to save and return to the Setup menu.

### 3.18 Changing the touchscreen display themes



The touchscreen themes (i.e. icons and background colours) can be changed to one of the preset options. To change themes follow these steps:

1. 
2. Scroll to **Theme** and select.
3. In the **Change Theme** screen, use   to scroll through your available options. As you scroll, each theme will display on the touchscreen. Press  to select your theme and return to the Setup menu.

# 3. Setting up your HYDRIM

## 3.19 Creating a User Name





Up to four unique User Names can be created. To assign a User Name follow these steps:

1.  →  → 
2. Scroll to **User** and select.
3. To assign a user name, select **User Name** and use the alphabetic keypad to enter a name (up to 12 characters) and press **EN** to save.



## 3.20 Creating a User PIN

From the User PIN screen, you can assign up to four PINs. To assign a PIN, follow these steps:

1.  →  → 
2. Scroll to **User** and select.
3. To assign a user PIN, select **User PIN** and use the numeric keypad to enter a number (up to 4 digits) and select **EN** to save and  to move to the confirmation screen.

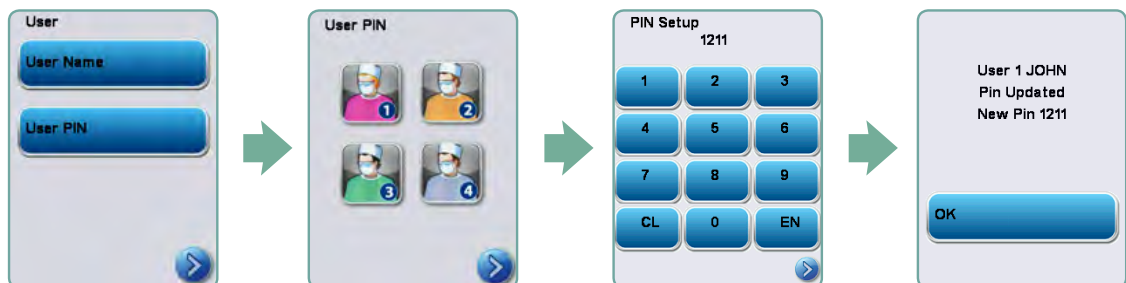







4. If all of the information presented in the confirmation screen is correct, press OK to be returned to the User PIN screen. To make a correction, select the User PIN you want to change and repeat the process described above.



# 3. Setting up your HYDR/M

## 3.21 Setting up process enforced usage

When process enforced usage is activated, users are required to enter a PIN at the end of a cycle. For process enforced usage to function, User IDs and PINs must first be assigned. To set up User ID and PINs, refer to sections 3.19 and 3.20 on creating a user name and PIN. To activate process enforced usage, follow these steps:

1.  →  → 
2. Scroll to **Process Enforced** and select.
3. Use   to toggle process enforced function ON or OFF. Press  to save your selection and return to the Setup menu.



**NOTE:** Any user can stop a cycle even with process enforced usage ON. However, the cycle data will record that an unauthorized user has stopped the cycle.



## 3.22 Connecting to a network

The HYDR/M C61w G4 has a 10/100Base-T Ethernet port located at the back of the unit. To connect your HYDR/M to a network using a router, follow these steps:

1. Connect your network cable to the Ethernet port at the back of the unit. If your office uses a router, the router should automatically assign the unit an IP address. A red X on the network icon means the unit is not connected. A yellow check mark means the unit has an IP address but is not connected to the Internet and cannot send emails. A green check mark means the Internet connection is set up properly and the unit can send out emails.



**NOTE:** In some circumstances, where you do not have a router, for example when using Windows Network Sharing, you may have to assign a dedicated or 'static' IP address. To assign a static IP address, contact your local network administrator.

2. From the main screen, press the Network icon. The Network screen displays information about your HYDR/M's connectivity, including its IP address.

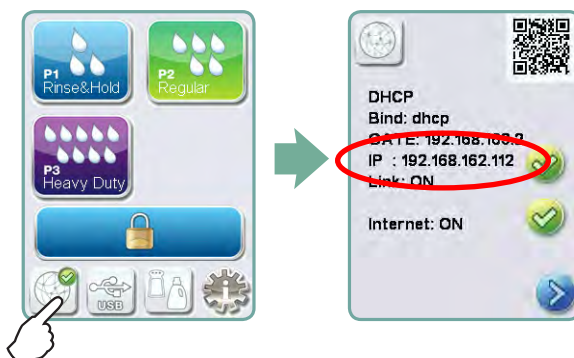

### 3. Setting up your HYDRIM

3. Type the IP address displayed on the touchscreen into the browser of any web enabled device to access your unit's web portal. When the Network icon is active (for example when sending email) it will turn green.

**NOTE:** Use QR code if connecting to a mobile device.

**NOTE:** Connection time will vary depending on your network speed, and making an initial connection can take longer.

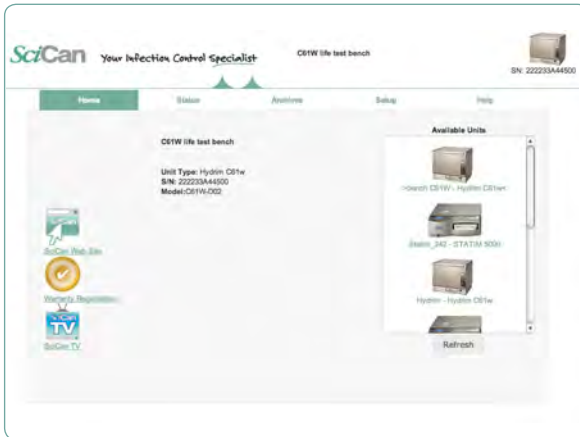

#### 3.23 Connecting to a wireless network

The HYDRIM can be configured for wireless use by connecting the Ethernet port to an external wireless bridge / access point. SciCan currently recommends the use of the D-Link® DAP-1522 Xtreme N® Duo Wireless Bridge. Contact your network administrator to learn more about setting up a wireless bridge.

## 4. Using your HYDR/M

### 4.1 Instrument reprocessing recommendations

The HYDR/M C61w G4 is designed to clean general dental and medical instruments. When used correctly, the HYDR/M is effective for the removal of debris on instruments that may result in the insulation of microorganisms during terminal sterilization.

**Note: Terminal sterilization must follow processing in the HYDR/M C61w G4.**

Examples of medical and dental instruments suitable for cleaning in the HYDR/M include:

- Stainless steel scalers, spatulas and hemostats.
- Stainless steel retractors, needle holders, skin hooks, tissue forceps, scissors, curettes, and other stainless steel instruments free of deep cavities.

For best results, instruments processed in the HYDR/M should have the following properties:

- Heat resistance to a temperature of up to 60°C.
- Corrosion resistance in the presence of heat.



Microkeratomes, phaco tubing, fiberoptics and electrical equipment should not be processed in the HYDR/M.



Nickel-plated instruments, or instruments containing aluminum or colour anodized aluminum as well as single use instruments are not suited for processing in the HYDR/M.

HIP™ Ultra (HYDR/M cleaning solution with Instrument Protection) has been carefully formulated to provide outstanding material compatibility with a wide range of metals and coatings. However, some manufacturers' instruments may not be compatible.

Some instrument manufacturers make their instruments with special coatings, which may not be suitable for the use in an automatic instrument washer. Please consult the instrument manufacturer for their recommended cleaning procedures of these instruments.



In general, it is not recommended to process carbon steel and chrome-plated instruments in the HYDR/M C61w G4.



When processing small or light objects in the HYDR/M C61w G4, use the basket with lid.



Do not put dental burrs in the HYDR/M C61w G4.

## 4. Using your HYDR/M

### 4.2 Cycle description chart

#### HYDR/M C61w G4 instrument washer

Cycle	Prewash	Wash	Rinse	Dry
<b>P0 – Machine Cleaning Cycle</b> No initial draining.	<30°C (cold) 2 minutes	N/A	<30°C (cold) 2 minutes	N/A
<b>P1 – Rinse and Hold Cycle</b> Use to prevent soil from drying on instruments when they will not be washed within one hour.	<30°C (cold) 2 minutes	N/A	<30°C (cold) 1 minutes	N/A
<b>P2 – Regular Cycle</b> Use for moderately soiled loose instruments.	<30°C (cold) 2 minutes	50°C 5 minutes	60°C 1 minute	1-25 minutes (default 10 minutes)
<b>P3 – Heavy Duty Cycle</b> Use for heavily soiled instruments and cassettes.	<30°C (cold) 2 minutes	50°C 9-15 minutes	60°C 1 minute	1-25 minutes (default 10 minutes)

# 4. Using your HYDRIM

## 4.3 Baskets and accessories



Observe the instrument manufacturer's recommendations for cleaning and care. When loading the unit, arrange loose instruments so that they do not touch one another. Instruments with concave surfaces or cavities should be placed so that water can drain freely.

**Baskets**

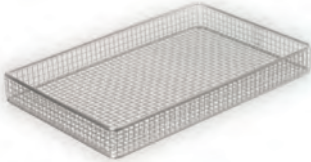

STATIM 2000 basket  
01-107240

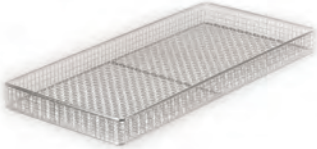

STATIM 5000 basket  
01-107241



Large basket  
01-113545

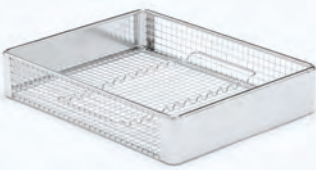

Hygiene Basket  
01-113546



Basket with hinged lid  
01-113547

**Racks (Trolley and baskets not included)**



Six cassette rack  
01-113251



Three cassette, two basket rack  
01-113253

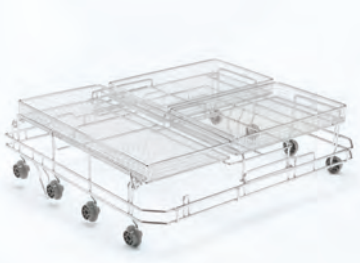

Two basket rack  
01-113257

**Rack for Vertical and Hinged Instruments**  
Requires support from a basket

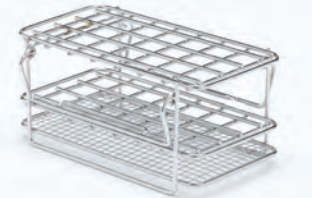

Rack for vertical instruments  
01-113255

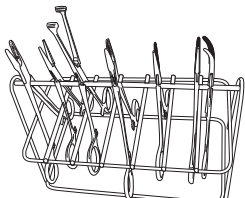

Rack for Hinged instruments  
01-110409S



Ten tray, two basket rack  
01-113254

## 4. Using your HYDR/M

### 4.4 Hints and tips for best cleaning results

- Remove all cement, composite material and amalgam from instruments at chairside prior to processing in the HYDR/M.
- Use only accessories, such as baskets, cassettes, trolleys and racks to hold instruments that are designed for the HYDR/M C61w G4.
- Use accessories for their intended purpose only. For example, do not place hinged instruments in cassettes. Use the hinged instrument rack instead.
- Disassemble instruments if possible.
- Do not overlap instruments. Each instrument must be kept separate.
- All instruments must be placed in the instrument washer in such a way as to allow good rinsing of all surfaces. Any surface that is shielded from water and detergent cannot be cleaned.
- Hinged instruments should be placed in a wide open position in baskets. Closed hinged instruments cannot be cleaned.
- Place suction tubes in the rack for vertical instruments and ensure that water can flow unrestricted in and out of the tubes. Do not place suction tubes horizontally in a basket or in a cassette. For instruments containing lumens, such as dental handpieces, only the external surfaces are cleaned.
- Place trays and other concave shaped items at an angle to ensure water can run off surfaces easily.
- Do not overload the HYDR/M.
- Verify the HYDR/M setup:
  - Ensure that the washer spray arms are free of any blockage and can rotate freely.
  - Ensure that the mesh filters in the chamber drain are free from debris.
- To achieve best cleaning results, instruments should be processed in the HYDR/M as soon as possible. If immediate cleaning is not possible, it is recommended to process the instruments using the P1 Rinse and Hold program immediately after use on the patient.
- Visually inspect instruments for cleanliness and integrity (corrosion, material changes) after cleaning and repair or replace instruments if necessary.
- If process enforced is activated, the operator must confirm that the instruments are visually clean after a complete cycle is finished.

## 4. Using your HYDR/M

### 4.5 Recommended load configurations

The HYDR/M C61w G4 can process many different instrument combinations as determined by the following:

- Size of practice
- Types of procedures undertaken at any one time
- Specialization of practice
- Instrument management protocols

Below are examples of a few loading scenarios, including the most common basket loadings, the recommended loading of general instruments, and the worst case loading for the unit. Handle all instruments with care to prevent personal injuries from punctures, for example, and follow local health and safety regulations to prevent accidents and injuries.

#### Using baskets and accessories

Observe the instrument manufacturer's recommendations for cleaning and care. When loading the unit, arrange loose instruments so that they do not touch one another. Instruments with concave surfaces or cavities should be placed so that water can drain freely.

Sample loading:

#### Solid straight and hinged instruments

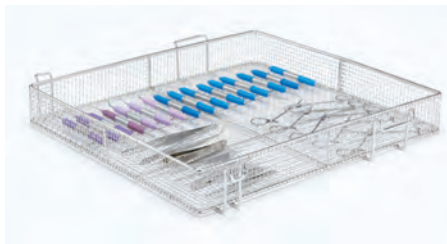

For example:  
scalpels, scissors,  
curettes, excavators,  
pluggers, etc.

#### Solid straight instruments

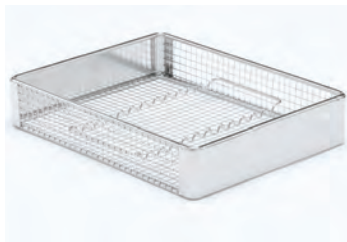

For example:  
pliers, knives,  
explorers, scalers,  
etc.

## 4. Using your HYDRIM

### Hinged instruments, solid instruments and open hollow instruments

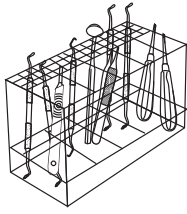

For example:  
Scalers, curettes,  
dental elevators,  
single part mirrors,  
suction tubes etc.

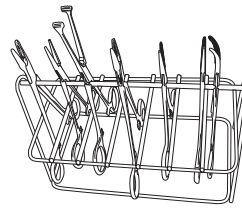

For example: Tissue  
forceps and scissors.

### Small and disassembled instruments

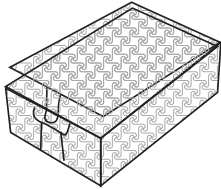

For example: Two piece mirrors, scalpel knife handles, etc.

### Instrument sets in cassettes – full load

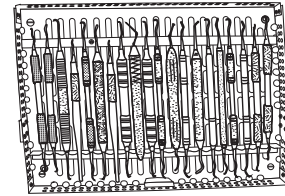
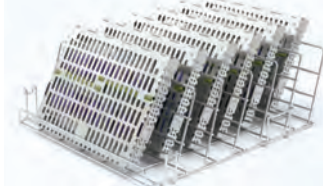
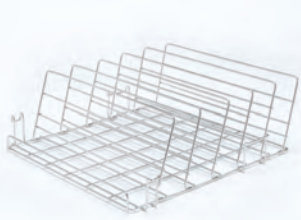

For example: Bone files, pluggers, curettes, excavators, etc.



## 4. Using your HYDR/M

### 4.6 Running a cycle

Before using your HYDR/M, check that the water supply is on and that the HIP™ Ultra cleaning solution bag is correctly installed and attached, then follow these steps:

- 1** Power unit on.



- 2** Touch the screen to begin.



- 3** Press UNLOCK if required.



- 4** Load instruments into the baskets or cassettes, place them in the machine and close the door.



- 5** Select the desired cycle. (Use a heavy duty cycle for cassettes, hinged instruments or heavily soiled instruments.)



- 6** Press START.



- 7** The cycle will begin.

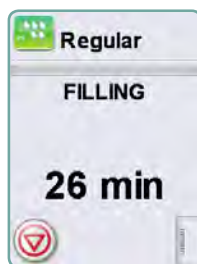

The cycle will start by draining the unit. The bar on the screen indicates the progression of the cycle. The stage within the cycle is shown beneath the bar (e.g. Filling, Rinsing). The estimated time remaining (in minutes) is always displayed. Please note that the time will increase or decrease depending on the projected cycle completion.

- 8** The cycle is complete.

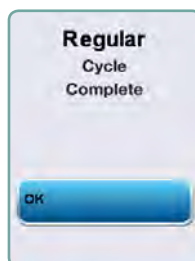

When the cycle is complete, the program name and “Cycle Complete” is displayed, and the unit beeps three times. Press “OK” to open the door. Use gloves to unload the instruments. After all cycles, exercise caution as the instruments, trolley, baskets and cassettes may be hot. Inspect the instruments for debris prior to packaging / sterilizing.

## 4. Using your HYDRIM

### 4.7 Interrupting / aborting a cycle

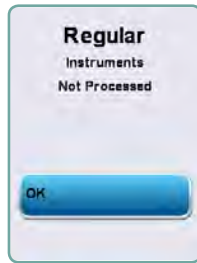

The door of the HYDRIM is locked during the cycle. If the STOP button is pressed, the cycle is aborted and cannot be re-started. The message “Draining. Please wait” will appear. The unit will drain. Then the message “Instruments not processed” will appear. Press OK. Open the door by pressing . Use gloves if handling the instruments. Exercise caution as instruments, trolley, baskets and cassettes may be hot. The cycle must be repeated to ensure that instruments are properly processed.



**NOTE:** If the drying phase of the cycle is interrupted, the critical parts of the cycle are complete and the message displaying the program name and “Cycle Complete. Drying interrupted” will appear.

### 4.8 Additional user and setup menu functions

To access the user or setup menus, follow these steps:

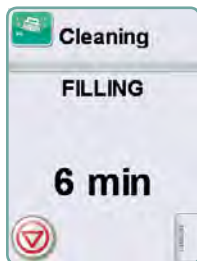

#### Chamber cleaning

This cycle is used to periodically remove hardwater deposits from the chamber walls and racks. Pour 0.5 litres of vinegar or citric acid-into the chamber before starting the cycle. The HYDRIM will remind you to run a cleaning cycle every 25 cycles. The reminder frequency can be adjusted by the technician. Touch “cleaning.” A cleaning cycle, similar to a normal wash cycle, will run. Failure to clean the chamber can promote corrosion.



#### Set drying time

The drying times for P2 and P3 can be set independently. Touch the cycle for which you want to set the drying time. Use the up and down arrows to select the desired drying time. Touch “default” if you wish to return to the factory default. Use the back arrow to return to the previous screen.

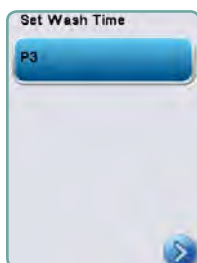

#### Set wash time

The wash time for P3 can be set independently. Touch the cycle for which you want to set the wash time. Use the up and down arrows to select the desired wash time. Touch “default” if you wish to return to the factory default. Use the back arrow to return to the previous screen.

## 4. Using your HYDRIM



### Cycle count

This allows the user to see how many cycles have been run on the HYDRIM. Touch cycle count and the number of cycles (completed and aborted) will be displayed. This cannot be reset. Touch the back arrow to return to the previous menu.



### Instructions

Users can access a database of pictorial instructions on how to perform routine maintenance such as installing the cleaning solution.

### 4.9 Opening the door in case of a power failure



If there is a power failure, locate the lever on the top edge of the door, slide it to the right and pull the door open. Exercise caution! There may be fluid remaining in the unit and the instruments may be hot. If the cycle was interrupted, instruments should not be used and should be reprocessed.



## 5. Storing and Retrieving Cycle Information

The HYDRIM C61w G4 has an internal Data Logger capable of storing all the data on every cycle, whether successful or incomplete, for the lifetime of the unit. You can access this information through the touchscreen, through the web portal or by using a USB storage device.

### 5.1 Retrieving cycle information using the touchscreen

1. From the main menu, press the USB icon.
2. The unit will record up to the last five successful cycles and the last five incomplete cycles.

If you select a cycle from the list, it will display cycle information in a format similar to how it would be printed.



3. Use the arrow keys to scroll through and read.



**NOTE:** Regardless of whether you have a USB storage device attached to the unit or not, you can always see the last five successful cycles and the last five incomplete cycles.

Use the HYDRIM C61w G4 web portal to access all the cycle information stored on your HYDRIM from your computer. To connect your HYDRIM see section 3.22 Connecting to a Network.

# 5. Storing and Retrieving Cycle Information

## 5.2 Retrieving cycle information using the USB data back up

The USB storage device can be used to transfer cycle information stored in the unit to a computer. Best practice suggests this should be done once a week. To transfer data using the USB port, follow these steps:

1. Plug the USB storage device into the USB port.
2. The HYDRIM keeps track of what data has already been transferred to the USB storage device and will automatically load only new data. Data stored in the internal memory of the HYDRIM can be copied once only. Access to previously transferred information can be made from the web portal.
3. When the activity light on your USB storage device stops blinking or the USB icon on the LCD turns from a flashing green to a solid grey, remove the USB storage device and transfer the information to your computer.



**NOTE:** If you select the USB storage device icon from the main menu, you will only be able to view the last five complete cycles and the last five incomplete cycles. To view all the cycles stored on the USB storage device, you must use your computer.

**NOTE:** If you lose your USB storage device and would like to transfer your unit's cycle history to a new device, follow these steps:

1. Plug the new USB storage device into the USB port.
2. Select the USB icon.
3. From the cycle information screen, select the USB icon again.
4. Select Copy and the unit will copy all cycle information to the USB storage device.

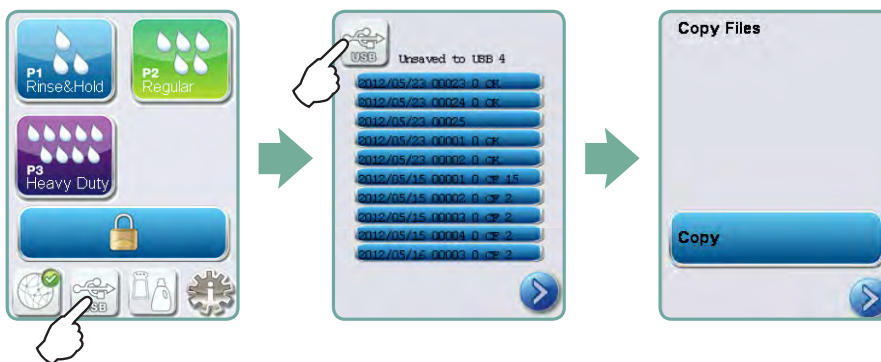

# 6. Care and Maintenance

## 6.1 Replacing the HIP™ Ultra cleaning solution

Only replace the cleaning solution with HIP™ Ultra cleaning solution, which is used in dilute form as a detergent for the cleaning of surgical instruments in the HYDRIM washer.

It is a colourless and almost odourless liquid that is completely soluble in water. Some precautions must be taken to safely handle this chemical. For more information, see section 3.2 Handling and Installing the HIP™ Ultra cleaning solution.

**NOTE:** To avoid spillage, replace the solution container only when the message appears and be sure to wear gloves.



When a red X appears on the water softener/detergent icon. Press on the icon to determine if the problem is with the water softener or cleaning solution level. If the cleaning solution must be replaced, a red X will appear next to it.

To replace the cleaning solution, follow these steps:  
Spare part#: CS-HIPC-U (8 x 750 mL), HIP™ Ultra cleaning solution.

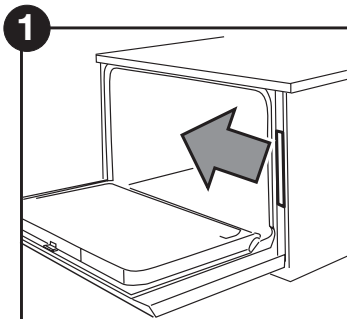

1 Turn the power OFF, open the door and pull out the chemical drawer.

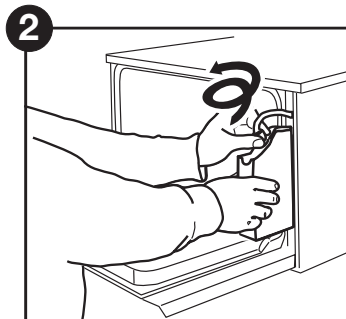

2 Disconnect the cleaning solution connector.

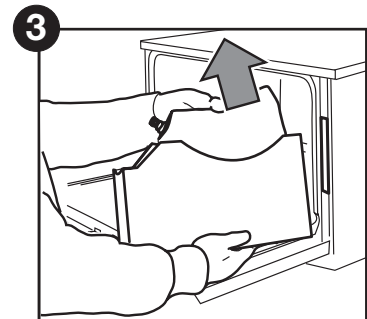

3 Remove the empty cleaning solution bag and discard or recycle it.

## 6. Care and Maintenance

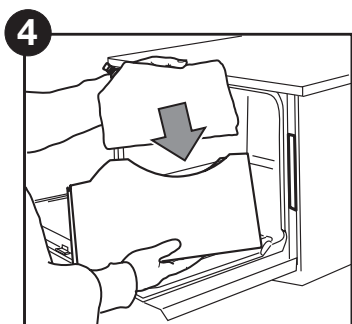

Place a new bag in the chemical drawer.

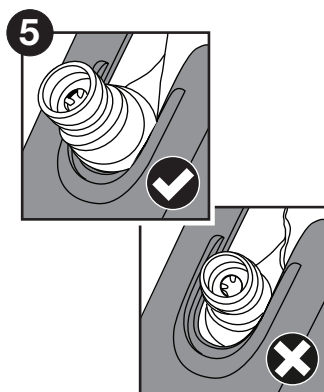

Ensure the nozzle is in the correct position.

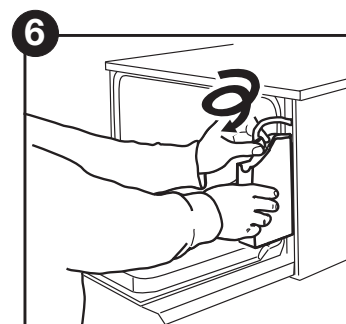

Connect the new bag, close the door and power ON the unit.

To prime the cleaning solution dosing pump, press the water softener/detergent icon on the main screen. In the water softener/detergent screen, press the red X next to “Detergent”. The unit will prime the dosing system and a green check mark will appear in place of the red X when it is ready for use.

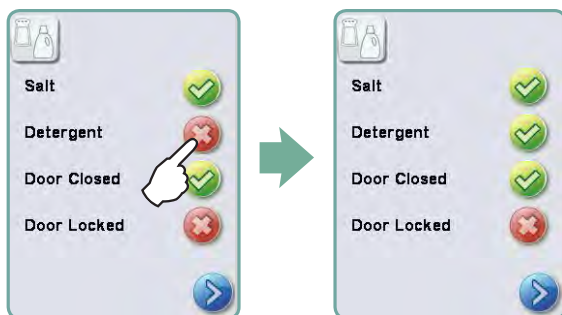



**NOTE:** The system can also be primed by simply starting a cycle and selecting “Detergent Replaced”, when prompted.

## 6. Care and Maintenance

### 6.2 Refilling the water softening salt reservoir

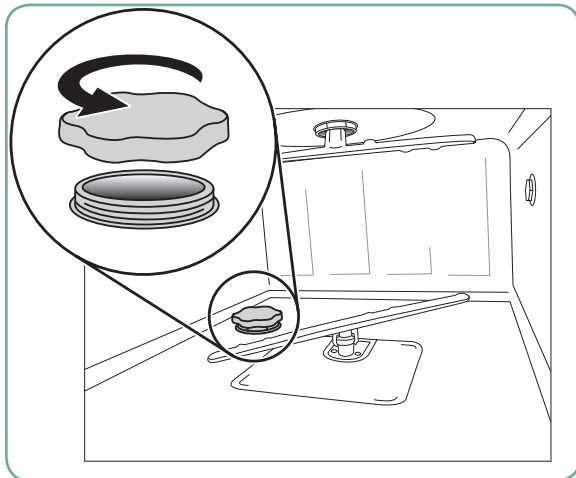
When a red X appears on the detergent and water softener level indicator, press on the icon to determine if the problem lies with the water softener or cleaning solution level. If the water softener must be refilled, follow these steps:



1. Open the salt container lid.
2. Fill the salt container to the top, using the funnel supplied, to a maximum of 0.5 kg.
3. Close the salt container lid, ensuring a tight seal. An improper seal can lead to corrosion. 
4. Run a complete cycle, with no instruments.

Spare part#: 01-112594S Salt, Water Softener

### 6.3 Changing the air filter

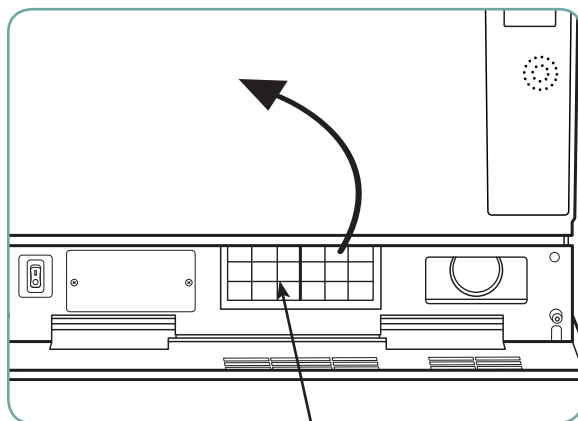

HEPA filter

When the message “Replace air filter” appears, the HEPA filter is in need of changing. Turn the power off. Pull open the ventilation panel below the front door of the unit. Make note of the direction of the arrow and remove the old filter by pulling it from the centre. Install the new air filter – placing the arrow in the correct orientation – and close the ventilation panel.

After replacing the filter, go to the “Reset Drying Counter” screen in the Setup menu and reset the drying counter to zero. (See Section 3.11)

The filter must be replaced every 750 drying cycles. The unit will continue to run if the filter is not replaced, but you will notice less than optimal drying performance.

Spare part#: 01-113277S Filter-Air, C61



## 6. Care and Maintenance

### 6.4 Filter and wash arm maintenance

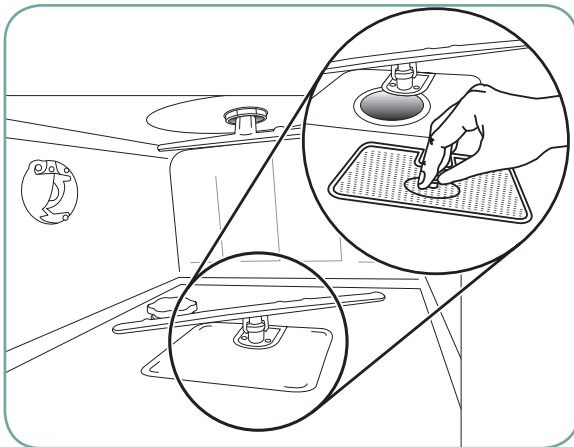

#### Filter maintenance

Inspect the coarse and fine filters in the bottom of the chamber daily for debris and clean if necessary. To clean, remove the filter (turn the metal nut at the centre front of the filter to release it), rinse under a tap and reassemble. Ensure that the filter is firmly locked into position when replaced.

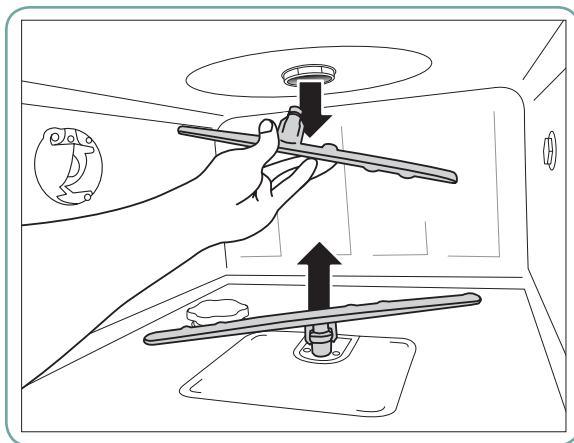

#### Wash arm maintenance:

If you see that the wash arms are not turning easily, remove the arm(s) as needed – excessive removal of wash arms can reduce service life. Both the upper and lower arms are pressure mounted. To remove the upper arm, pull down and to remove the lower arm, pull up. Rinse under a tap, clear obstructions from outlet holes and reassemble.

### 6.5 Cleaning the unit

To clean outer surfaces and the decal covering the touchscreen, use a soft cloth moistened with soap and water or a surface disinfectant. Do not use harsh cleaning chemicals.

To clean the chamber, use the “Cleaning” function available in the user menu with 0.5 L of vinegar or citric acid in the chamber. See section 4.8 for details.

**NOTE:** Every 25 cycles, the user will be reminded to run a chamber cleaning cycle.

Press OK to continue the selected wash cycle but remember to run a chamber cleaning cycle at the next available opportunity.

### 6.6 Preparing the unit for shipping

If preparing the unit for transport or storage, waste water should be removed from the sump. Waste water in the unit may contain biological contaminants. From the Setup menu, select the Prepare for Shipping function.



## 6. Care and Maintenance

The unit will pump all the waste water from the sump. If a small amount remains, soak it up with absorbent material. Wear disposable rubber gloves. Dispose of absorbent material according to biological waste disposal regulations.

If the unit is without power, use the drain tube located under the front of the unit in the middle to drain the water from the chamber and system. Then unlock the door using the door lever (see section 4.9) and remove the coarse filter and fine filter (see section 6.4) and use absorbent material to soak up any water remaining in the sump.

### 6.7 Annual maintenance

If the message “Preventative Maintenance Required. Call for Service” appears, the annual maintenance is required. To continue using the HYDRIM, press OK. Call for service as soon as possible. The annual maintenance should be done after 365 days have elapsed since the initial installation or since the last service call was performed.

### 6.8 Unit testing and validation

The following outlines the recommended regular maintenance to be performed by the user and technicians for the HYDRIM C61w G4 washer.

To ensure the unit's ongoing cleaning efficacy, SciCan recommends observing the following periodic testing protocols.

The recommended periodic testing protocols are listed in the table below:

When	Who	What Tests
<b>Upon installation</b>	By a SciCan-approved technician	<ul style="list-style-type: none"><li>• Commissioning/Installation testing as outlined in the installation document included with the unit.</li><li>• First validation if required by local regulations.</li></ul>
<b>Daily tests and checks</b>	By the user	<ul style="list-style-type: none"><li>• door lock check</li><li>• wash arm rotation check</li><li>• door seal check</li><li>• load carrier check</li><li>• check and clean chamber filters</li><li>• visual examination (inspection under magnification) of each load for residual soil.</li></ul>
<b>Annually</b>	By a SciCan-approved technician	<ul style="list-style-type: none"><li>• Annual maintenance schedule as outlined in the service manual</li></ul>
<b>Bi-Annually</b>	By a SciCan-approved technician	<ul style="list-style-type: none"><li>• Re-validation if required by local regulations.</li></ul>

## 6. Care and Maintenance

### IMPORTANT NOTES:

- This document outlines the minimum requirements to ensure that the equipment performs to specification. In some regions, local/national guidance documents may require additional testing. Please contact your dealer or local medical authorities for details.
- Installation, commissioning, annual servicing **MUST** be undertaken by SciCan approved technicians. Failure to maintain this equipment may invalidate the results of the following testing regime.

### Tests to be performed by the user:

#### Door lock check

This test is to ensure that the door cannot be opened while a cycle is running or a cycle will not start with the door open. To check that these features are working correctly, attempt to open the door using the handle immediately after a cycle has started. **Caution – DO NOT attempt this when the wash arms are rotating and/or the water is above ambient temperature.** The door should not open. When you attempt to start a cycle with the door open, the cycle should not start. If the unit fails this test, stop using it immediately and call your dealer for technical service.

#### Door seal check

Visually check the door seal for debris or wear. If the seal is worn or damaged, call your dealer for technical service.

#### Load carrier check

Visually check load carriers (trolleys) for wear and tear, damage and that the runners move freely over their full range.

#### Chamber filter check

Remove, visually check and clean as described in section 6.4.

#### Load check

Visually inspect each load for residual soil. Washers are designed to ensure that the surfaces of instruments are free from debris that may compromise the sterilization process. A visual check of the instruments processed in each load should be undertaken prior to sterilization to ensure that no residual debris is present on the instrument.

If debris is still apparent, the instrument should not be considered clean and should be reprocessed through the HYDRIM again prior to sterilization.

**NOTE:** Some set-able materials such as cements and composites, if set on the instrument will not be removed in a HYDRIM. If these materials are noticed on the instrument then abrasive removal may be required.

## 7. Troubleshooting

Problem	Possible Causes and Solutions
<b>Instruments are not clean</b>	<ul style="list-style-type: none"> <li>• Do not overload cassettes or instrument baskets.</li> <li>• Do not load too many cassettes into the HYDRIM.</li> <li>• Use the Heavy Duty cycle for cassettes and hinged instruments.</li> <li>• Check filters and wash arms for debris.</li> <li>• Increase wash times. See section 4.8.</li> </ul>
<b>Touchscreen / Unit does not come on</b>	<ul style="list-style-type: none"> <li>• Ensure that the power button is turned ON.</li> <li>• Ensure that the plug is properly inserted into the wall socket.</li> <li>• Check if a fuse or circuit is blown – call service for assistance.</li> </ul> <p>NOTE: Fuses should NOT be replaced by the operator. Call an authorized service technician for assistance. For continued protection against the risk of fire, replace only with 15A, 250V type F fuses.</p>
<b>The wash arms do not rotate</b>	<ul style="list-style-type: none"> <li>• Remove the wash arms, clean and reinstall them.</li> <li>• Check for obstructions in chamber.</li> </ul>
<b>The door cannot be opened</b>	<ul style="list-style-type: none"> <li>• The cycle is not complete.</li> <li>• The cycle was aborted and the unit has not completed draining yet.</li> </ul>
<b>Operating cycles appear to be taking too long to complete</b>	<ul style="list-style-type: none"> <li>• The water is not hot enough. Check that the incoming hot water temperature is in the recommended range.</li> <li>• Check that the hot and cold hoses are not reversed.</li> </ul>
<b>“No detergent” message comes on but there is still a lot of chemical left in the container</b>	<ul style="list-style-type: none"> <li>• Check for a kink in chemical tubing.</li> <li>• Check cap for seal.</li> <li>• Reinstall chemical solution, see section 6.1</li> </ul>
<b>Drying performance is inadequate</b>	<ul style="list-style-type: none"> <li>• Increase the drying time. See section 4.8.</li> <li>• Change the HEPA filter. spare part#: 01-113277S Filter-Air, C61</li> </ul>

## 7. Troubleshooting

<b>Problem</b>	<b>Possible Causes and Solutions</b>
<b>“Preventative Maintenance Required. Call for Service” message appears</b>	The annual maintenance should be done after 365 days have elapsed since the initial installation or the last service call was performed. Call for service.
<b>“Replace Air Filter” message appears</b>	<ul style="list-style-type: none"> <li>• Replace HEPA filter. See section 6.3.</li> <li>• If filter was replaced and message continues to appear, reset drying counter. See section 3.11.</li> </ul>
<b>“Air Filter Missing. Install Filter”</b>	<ul style="list-style-type: none"> <li>• Check HEPA filter to ensure it is installed correctly (with arrow in correct position).</li> </ul>
<b>Lost USB storage device with all cycle data</b>	<p>If you need to copy all of the unit’s cycle data to a new USB storage device:</p> <ol style="list-style-type: none"> <li>1. Insert the new USB device.</li> <li>2. Select the USB icon.</li> <li>3. Select cycle information.</li> <li>4. From the cycle information screen, select the USB icon at top right.</li> <li>5. Select copy and all of the unit’s cycle history will be copied to the new device.</li> </ol>
<b>No Internet Connection</b>	<p>Select the connectivity icon to go to the connection status screen.</p> <ul style="list-style-type: none"> <li>• If a red X appears next to IP: You do not have a network connection. Contact your network administrator.</li> <li>• If a red X appears next to Internet: You do not have an Internet connection. Contact your Internet provider.</li> </ul>

## 7. Troubleshooting

### Error Messages

<b>Error</b>	<b>What it Means</b>	<b>What to Do</b>
<b>CF1 Water Heating failure</b>	The water does not reach the required temperature in the specified time.	<ul style="list-style-type: none"> <li>• Call for service.</li> </ul>
<b>CF2 Chamber Filling Failure</b>	The water does not fill the chamber within the specified time.	<ul style="list-style-type: none"> <li>• Check that the water hoses are not kinked. Open the water shut-off valves.</li> </ul>
<b>CF3 Chamber temperature reading failure</b>	Faulty sensor.	<ul style="list-style-type: none"> <li>• Call for service.</li> </ul>
<b>CF4 Water evacuation failure</b>	Water cannot drain from the unit.	<ul style="list-style-type: none"> <li>• Check that the drain hose is not kinked.</li> <li>• Check that the filters in the bottom of the chamber are not obstructed.</li> <li>• Check that the drain outlet is within the specified height noted in the installation manual.</li> </ul>
<b>CF7 Cycle Aborted or Interrupted</b>	Power failure.	<ul style="list-style-type: none"> <li>• Restore power to the unit.</li> <li>• Restart program.</li> </ul>
<b>CF9</b>	System failure.	<ul style="list-style-type: none"> <li>• Call for service.</li> </ul>
<b>CF10 Drying System Error</b>	Problem with drying.	<ul style="list-style-type: none"> <li>• Call for service.</li> </ul>
<b>CF11 Dosing System Error</b>	Problem with detergent system.	<ul style="list-style-type: none"> <li>• Call for service.</li> </ul>

## 7. Troubleshooting

<b>Error</b>	<b>What it Means</b>	<b>What to Do</b>
<b>CF15 Water Reservoir Overflow</b>	Water reservoir overflow switch triggered.	<ul style="list-style-type: none"> <li>Restart program.</li> <li>Call for service.</li> </ul>
<b>CF16 Ambient Temperature Error</b>	Unit is too hot or has overheated.	<ul style="list-style-type: none"> <li>The room or enclosure is too warm and not allowing the unit to adequately cool.</li> <li>If message persists, call for service.</li> </ul>
<b>CF17 Air Drying Error</b>	Drying system overheated.	<ul style="list-style-type: none"> <li>Check HEPA filter</li> <li>Check if air exhaust is blocked</li> <li>If message persists, call for service.</li> </ul>
<b>CF21 Dosing Pump Failure</b>	Chemical dispensing system error.	<ul style="list-style-type: none"> <li>Tighten detergent cap.</li> <li>Check for detergent leak.</li> <li>If message persists, call for service.</li> </ul>
<b>CF22 Air Temperature Error.</b>	Faulty sensor.	<ul style="list-style-type: none"> <li>Call for service.</li> </ul>
<b>CF23 Top wash arm low RPM</b>	Top wash arm speed too low.	<ul style="list-style-type: none"> <li>Check that load is not blocking wash arm.</li> <li>Check all holes in wash arms for debris.</li> <li>If message persists, call for service.</li> </ul>
<b>CF24 Bottom wash arm low RPM</b>	Bottom wash arm speed too low.	<ul style="list-style-type: none"> <li>Check that load is not blocking wash arm.</li> <li>Check all holes in wash arms for debris.</li> <li>If message persists, call for service.</li> </ul>
<b>CF25 Reference voltage Error</b>	System failure.	<ul style="list-style-type: none"> <li>Call for service.</li> </ul>

## 8. Warranty

### Limited Warranty

For a period of one year, SciCan guarantees that the HYDR/IM C61w G4, when manufactured in new and unused condition, will not fail during normal service due to defects in material and workmanship that are not due to apparent abuse, misuse, or accident. In the event of failure due to such defects during this period of time, the exclusive remedies shall be repair or replacement, at SciCan's option and without charge, of any defective part(s), provided SciCan is notified in writing within thirty(30) days of the date of such a failure and further provided that the defective part(s) are returned to SciCan prepaid.

This warranty shall be considered to be validated, if the product is accompanied by the original purchase invoice from the authorized SciCan dealer, and such invoice identifies the item by serial number and clearly states the date of purchase. No other validation is acceptable. After one year, all SciCan's warranties and other duties with respect to the quality of the product shall be conclusively presumed to have been satisfied, all liability therefore shall terminate, and no action or breach for any such warranty or duty may thereafter be commenced against SciCan.

Any express warranty not provided hereon and any implied warranty or representation as to performance, and any remedy for breach of contract which, but for this provision, might arise by implication, operation of law, custom of trade or course of dealing, including any implied warranty of merchantability or of fitness for particular purpose with respect to all and any products manufactured by SciCan is excluded and disclaimed by SciCan.

To register your product warranty with SciCan, go to [Scican.com](http://Scican.com), click on the appropriate country, and then click on the Register Your Warranty tab.



## 9. Specifications

<b>Machine dimensions:</b>	Length:	52 cm	20.5"
	Width:	59.8 cm	23.5"
	Depth:	52.6 cm	20.7"
	Depth with door open:	82.9 cm	32.6"
<b>Weight :</b>		44 kg	97 lbs
<b>Running noise:</b>		65 dB	
<b>Hot and cold water connections</b>		G 3/4"	
<b>Inlet water pressure:</b>		1-10 bar	
<b>Incoming hot water temperature:</b>		60°C	140°F
<b>Drain:</b>		3/4"	
<b>Drying system:</b>		Heater 1 kW	
<b>Electrical connection:</b>		208-240VAC ±10%, single-phase, 60 Hz, 12A	
<b>Protection class:</b>		Class I	
<b>Equipment pollution degree:</b>		Pollution degree 2	
<b>Equipment installation category:</b>		Installation category II	
<b>Maximum relative humidity:</b>		80% for temp up to 31°C/88°F 50% for temp up to 40°C/104°F	
<b>Operating temperature range:</b>		5°C - 40°C	41°-104°F
<b>Max. altitude:</b>		2000 m	6,562 feet
<b>Mains supply:</b>		+ / -10% of nominal	
<b>Fuses:</b>		15A, 250V, Type F	



## MERCOFRAMES OPTICAL CORP

5555 Nw 74 Ave. Miami, Fl 33166 305-882-0120

www.mercoframes.com sales@mercoframes.net